



## **Biscoe Town Council Meeting Agenda for October 14, 2019 at 7:00 pm**

1. Call to Order **Mayor Blake**  
Moment of Silence  
Pledge of Allegiance to the Flag  
Statement of Disclosure/Conflict of Interest Statement
  
2. Agenda Adjustments and Approval **Mayor Blake**
  
3. Consent Agenda **Mayor Blake**
  - a) Approval of September 9, 2019 Regular Meeting Minutes
  - b) Approval of September 25, 2019 Special Meeting Minutes
  - c) Approval of Amended June 10, 2019 Minutes
  - d) Approval of October Monthly Financial Report
  
4. Chief T. Shane Armstrong Oath of Office **Town Clerk Laura Morton**
  
5. Annexation of New Road **Manager Holland**
  
6. Approval of Bid Proposals for the Shady Oak Pump Station **Manager Holland**
  
7. Census Committee **Town Clerk Laura Morton**
  
8. Set Public Hearing Conditional Use Application **Manager Holland**  
LeCraw Engineering – 101 Montgomery Crossing
  
9. Public Comment
  
10. Mayor’s Minutes - Commissioner Reports - Staff Reports
  
11. Adjournment

## Statement of Disclosure/Conflict of Interest Statement

---

### ***Based upon New Rules of Procedure Policy Adopted by the Board September 9, 2019***

*Town of Biscoe Code of Ethics provides that public officials and employees be independent, impartial and responsible to the public; that governmental decisions and policy be made in proper channels of the governmental structure; that public office not be used for personal gain; and that the public have confidence in the integrity of its government. In recognition of these goals and in keeping with the ethical standards of conduct for town public officials and its employees, disclosure of interest in legislative action must be stated for the public record. The mayor or any member of the town council who has an interest in any official act or action before the council shall publicly disclose on the record of the council the nature and extent of such interest, and shall withdraw from any consideration of the matter if excused by the council pursuant to G.S. 160A-75.*

*“In keeping with the Conflict of Interest Laws outlined in Chapter 138A of the North Carolina Board of Ethics, any conflicts of interest or appearance of conflict with matters coming before the Board of Commissioners should be declared.” “Having received our agenda for this evening’s meeting, are there any conflicts of interest to be announced? If so please, state them at this time.”*

## **Agenda Adjustments and Approval**

---

This is a new agenda item Based upon

New Rules of Procedure Policy Adopted by the Board September 9, 2019

## Consent Agenda

- a) Approval of September 9, 2019 Regular Meeting Minutes
- b) Approval of Amended June 10, 2019 Minutes
- c) Approval of October Monthly Financial Report

*We are requesting the minutes from the last month's regular meeting and special called meeting be approved, as well as the June 10, 2019 minutes. These minutes had to be retyped because the file was lost.*

*The regular monthly financial report (MFR) for October is included for your review, questions and approval.*

**TOWN OF BISCOE  
BOARD OF COMMISSIONERS MEETING  
September 9, 2019**

The Biscoe Town Board of Commissioners met in a regular session on Monday, September 9, 2019 at 7:00 pm in the Municipal Building. Present were: Mayor Jimmy Blake, Mayor Pro-Tem Jerry Smith, Commissioners Gene Anderson, and Kay Cagle Kinch. Commissioner John Beard was absent. (James Cagle, Jr. "Jimmy" Cagle's seat is vacant due to his death on December 30, 2017).

*Members of Management Present: Town Manager Brandon Holland, Town Clerk Laura Morton, Public Works Director Sam Stewart and Interim Police Chief Shane Armstrong.*

**Call to Order/Pledge of Allegiance**

---

Mayor Blake called the meeting to order at 7:00 pm. The Pledge of Allegiance to the American Flag was recited and a moment of silence was observed.

**Conflict of Interest Statement**

---

"In keeping with the Conflict of Interest Laws outlined in Chapter 138A of the North Carolina Board of Ethics, any conflicts of interest or appearance of conflict with matters coming before the Board of Commissioners should be declared," "Having received our agenda for this evening's meeting, are there any conflicts of interest to be announced? If so, please, state them at this time."

**Approval of the Consent Agenda**

---

*A motion was made by Mayor Pro-tem Smith, seconded by Commissioner Kinch and so the motion carried unanimously to approve consent agenda items:*

- a) Approval of the Agenda
- b) Approval of August 12, 2019 Regular Meeting Minutes
- c) Approval of September Monthly Financial Report

AYES: 3; NAYS: 0

**Budget Amendments**

---

*A motion was made by Commissioner Anderson, seconded by Mayor Pro-tem Smith, and so the motion carried unanimously to approve the following Budget Amendments:*

*Budget Amendment #2*

Public Works      Approval of Purchase Order for Purser Rewinding in the amount of \$5,339.30.  
(Budget Code 60-7100-550)

<u><i>GL Account Number</i></u>	<u><i>Date</i></u>	<u><i>Debit</i></u>	<u><i>Credit</i></u>
<i>60-3991-000 Fund Balance Appropriated</i>	<i>9-09-2019</i>		<i>5,339.30</i>
<i>60-7100-550 Capital Outlay</i>	<i>9-09-2019</i>	<i>5,339.30</i>	

Budget Amendment #3

Fire Department OSFM Grant – Approval of Moving \$60,000  
from Fire Department Capital Outlay to 2019 OSFM Grant  
(Budget Code 10-4340-550 to 10-4340-002)

<u>GL Account Number</u>	<u>Date</u>	<u>Debit</u>	<u>Credit</u>
10-4340-550 Capital Outlay	9-09-2019		60,000.00
10-3991-000 Fund Balance	9-09-2019		60,000.00
10-3991-000 Fund Balance	9-09-2019	60,000.00	
10-4340-002 2019 OSFM	9-09-2019	60,000.00	

AYES: 3; NAYS: 0

**Approval of Policies**

---

*A motion was made by Commissioner Kinch, seconded by Commissioner Anderson, and so motion carried unanimously approve the Biscoe Town Council Rules of Procedure Policy, Approval of Biscoe Surplus Property Policy, and the Personnel Policy Amendments. (Attachments 1, 2, 3)*

AYES: 3; NAYS: 0

**Approval of RFP for Legal Services for CDBG-I – Bruton Street Project**

---

Manager Holland said a Request for Proposals for Legal Services for the CDBG-I – Bruton Street Project was sent out on 2 separate occasions and only one proposal was received. That proposal was from Town Attorney Russell Hollers III (Hollers & Atkinson). Manager Holland explained that because only one proposal was received a letter to the state would need to be sent explaining the process.

*A motion was made by Mayor Pro-tem Smith, seconded by Commissioner Kinch, and so the motion carried unanimously to award the RFP for Legal Services for CDBG-I – Bruton Street Project to Russell Holler III (Hollers & Atkinson).*

AYES: 3; NAYS: 0

*RFP Attached (Attachment 4)*

**New Speed Bump Request**

---

*A motion was made by Mayor Pro-tem Smith, seconded by Commissioner Anderson, and so the motion carried unanimously approve an additional speed bump for Church Street.*

*Mayor Blake directed Public Utility Director Sam Stewart to look into having a speed bump on this street.*

AYES: 3; NAYS: 0

**Police Department Presentation**

---

Interim Police Chief Shane Armstrong and Sergeant Tina Medlin gave a presentation on the Town's new Community Policing Council. The meetings will be held in the Meeting Room at Town Hall every month. (Attachment 5)

**Mayor's Minutes - Commissioner Reports - Staff Reports**

---

Mayor Blake invited the Board to attend a Piedmont Triad Regional Council event at the Zoo on October 14 at 2 pm.

Mayor Blake said he attended a 100<sup>th</sup> birthday party for Ms. Maness held by Ms. Hinson. He also attended the Labor Day Breakfast at the Good Ole Boys Club organized by Gene Stevens.

Mayor Blake announced there is a new business opened on Shady Oak at the Old Lynn Dean Building. They make maternity clothes. The business has new updated equipment.

Manager Holland said plans for the Bruton Street Project have been designed and submitted to the State. He also updated the Board on the Shady Oak Pump Station Renovation.

**Public Comment**

---

The following spoke during the public forum:

*Mr. Tom Dowd* of 125 Industrial Drive and 495 Cedar Creek Road was present. He thanked the Board and Sam Stewart for the No Parking Signs. He asked why business owners in Biscoe aren't allowed to run for public office. Mayor Blake said that is up to the General Assembly and the State Board of Elections.

*Mr. Johnie Harris* of 658 Bruton Street Extension was present. He voiced his concerns about the Biscoe Police Department. He asked for a follow-up on the topics he raised at the August 2019 meeting. These topics included safe zones, a diversity citizen review board, race training, and hiring of a minority officer. He asked if the officer had been fired. Mr. Harris also asked why Biscoe Police Salaries are so low. He also asked who is in charge of hiring and firing of employees.

Mayor Blake said Manager Holland is responsible for hiring and firing of all employees with the exception of the Town Clerk.

Manager Holland said he could not speak in an open meeting about an employee. He said he would meet with Mr. Harris and talk with him about what he is allowed to speak about on a one on one basis.

Benjy Dunn of Lake Drive thanked the Board for the speed bump on Church Street.

**Closed Session – Pursuant to NCGS 143-318.11 (a) (3) – Attorney Client Privilege**

---

It was decided there was no need for a closed session at this meeting.

**Adjournment**

There being no further business to bring before the Board, Commissioner Beard made the motion to adjourn, and Commissioner Kinch made the second. All voted in favor. Meeting adjourned at 7:45 p.m.

\_\_\_\_\_  
Mayor



\_\_\_\_\_  
Town Clerk

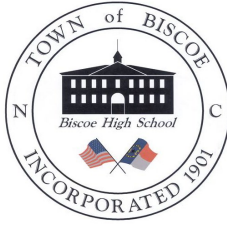

## **Suggested Rules of Procedure for a City Council**

### **Part I. Applicability**

#### **Rule 1. Applicability of Rules**

---

These rules apply to all meetings of the Biscoe Town Council. For purposes of these rules, a meeting of the council occurs whenever a majority of the council's members gather, whether in person or simultaneously by electronic means, to conduct hearings, deliberate, vote, or otherwise transact public business within the council's real or apparent jurisdiction. The term "majority" as used here and elsewhere in these rules means, unless otherwise specified, a simple majority, that is, more than half.

### **Part II. Quorum**

#### **Rule 2. Quorum**

---

The presence of a quorum is necessary for the council to conduct business. A majority of the council's actual membership plus the mayor, excluding vacant seats, constitutes a quorum. A member who withdraws from a meeting without being excused by majority vote of the remaining members in attendance is deemed present for quorum purposes.

### **Part III. Open Meetings**

#### **Rule 3. Remote Participation in Council Meetings**

---

No member who is not physically present for a council meeting may participate in the meeting by electronic means except in accordance with a policy adopted by the council. [Although a member who attends a meeting electronically pursuant to such a policy may take part in debate, the member may neither be counted toward a quorum nor vote on any matter before the council.]

#### **Rule 4. Meetings to Be Open to the Public**

---

Except as permitted by Rule 5, all meetings of the council shall be open to the public, and any person may attend its meetings.

#### **Rule 5. Closed Sessions**

---

**(a) Motion to Enter Closed Session.** The city council may enter a closed session from which the public is excluded only upon a motion duly made and adopted in open session. The motion to enter closed session must cite one or more of the permissible bases for closed session listed in paragraph (b) of this rule. A motion to enter closed session under subparagraph (b)(1) or (b)(2) must contain the additional information specified in those provisions.



**(b) Bases for Closed Session.** A closed session is permissible under the following circumstances and no others:

- (1) To prevent the disclosure of information that is privileged or confidential pursuant to the law of North Carolina or of the United States or that does not constitute a public record within the meaning of Chapter 132 of the General Statutes. The motion to enter closed session must name or cite the law that renders the information confidential or privileged.
- (2) To consult with the city attorney or another attorney employed or retained by the city in order to preserve the attorney–client privilege. If the council expects to discuss a pending lawsuit with its attorney, the motion to enter closed session must include the names of the parties to the lawsuit.
- (3) To discuss matters relating to (a) the location or expansion of industries or other businesses in the area served by the city or (b) the closure or realignment of a military installation. The council may reach agreement in closed session on a tentative list of economic development incentives to be offered in negotiations, but the approval of the signing of any economic development contract or commitment and the authorization of the payment of economic development expenditures must take place in open session.
- (4) To establish or instruct staff or agents concerning the city’s position in negotiating the price or other material terms of an agreement for the acquisition of real property by purchase, exchange, or lease.
- (5) To establish or instruct staff or agents concerning the amount of compensation or other material terms of an employment contract.
- (6) To consider the qualifications, competence, performance, character, fitness, or conditions of appointment or employment of a public officer or employee or prospective public officer or employee, except when the individual in question is a member of the city council or other public body or is being considered to fill a vacancy on the city council or other public body. Final action to appoint or employ a public officer or employee must take place in open session.
- (7) To hear or investigate a charge or complaint by or against a public officer or employee. Final action discharging an employee or removing an officer must occur in open session.
- (8) To plan, conduct, or hear reports concerning investigations of alleged criminal misconduct.
- (9) To view a law enforcement recording released pursuant to G.S. 132-1.4A.
- (10) On any other basis permitted by law.

**(c) Closed Session Participants.** Unless the council directs otherwise, the city manager, city attorney, and city clerk may attend closed sessions of the council. No other person may attend a closed session unless invited by majority vote of the council.

**(d) Motion to Return to Open Session.** Upon completing its closed session business, the council shall end the closed session by adopting a duly made motion to return to open session.

#### **Rule 6. Meeting Minutes**

---

**(a) Minutes Required for All Meetings.** The council must keep full and accurate minutes of all of its meetings, including closed sessions. To be “full and accurate,” minutes must record all actions taken by the council. They should set out the precise wording of each motion and make it possible to determine the number of votes cast for and against each motion. The minutes need not record discussions of the council, though the council in its discretion may decide to incorporate such details into the minutes.

**(b) Record of “Ayes” and “Noes.”** At the request of any member of the council, the minutes shall list each member by name and record how each member voted on a particular matter.

**(c) General Accounts of Closed Sessions.** In addition to minutes, the council must keep a general account of each closed session. The general account must be sufficiently detailed to provide a person not in attendance with a reasonable understanding of what transpired. The council may combine the minutes and general account of a closed session into one document, so long as the document contains both a complete record of actions taken and the level of detail required for a general account.

**(d) Sealing Closed Session Records.** Minutes and general accounts of closed sessions shall be sealed until unsealed by order of the council or, if the council delegates the authority to unseal to one or more staff members, in accordance with guidelines adopted by the council. The sealed minutes and general account of any closed session may be withheld from public inspection so long as public inspection would frustrate the purpose(s) of the closed session.

#### **Rule 7. Broadcasting and Recording Meetings**

---

**(a) Right to Broadcast and Record.** Any person may photograph, film, tape-record, or otherwise reproduce any part of a council meeting that must take place in open session. Except as provided in paragraph (c) of this rule, any radio or television station may broadcast any such part of a council meeting.

**(b) Advance Notice.** Any radio or television station that plans to broadcast any portion of a council meeting shall so notify the [city clerk/city manager/administrator] no later than [twenty-four hours] before the meeting. The failure to provide notice is not, by itself, grounds for preventing the broadcast of a council meeting.

**(c) Equipment Placement.** The [city manager/administrator] may regulate the placement and use of camera or recording equipment in order to prevent undue interference with a council meeting, so long as he or she allows the equipment to be placed where it can carry out its intended function. If the [city manager/administrator] determines in good faith that the equipment and personnel necessary to broadcast, photograph, or record the meeting cannot be accommodated without undue interference to the meeting, and an adequate alternative meeting room is not readily available, the [city manager/administrator] may require the pooling of the equipment and the personnel operating it.

**(d) Alternative Meeting Site.** If the news media request an alternative meeting site to accommodate news coverage, and the council grants the request, the news media making the request shall pay the costs incurred by the city in securing an alternative meeting site.

#### **Part IV. Organization of the Council**

##### **Rule 8. Organizational Meeting; Selection of [Mayor and] Mayor Pro Tempore**

---

**(a) Scheduling Organizational Meeting.** The council must hold an organizational meeting following each general election in which council members are elected. The organizational meeting must be held either (1) on the date and at the time of the council's first regular meeting in December following the election or (2) at an earlier date, if any, set by the incumbent council. The organizational meeting may not be held before municipal election results are officially determined, certified, and published as required by law.

**(b) Oath of Office.** As the first order of business at the organizational meeting, all newly elected members of the council must take and subscribe the oath of office set out in Article VI, Section 7, of the North Carolina Constitution. Each member's oath must be filed with the city clerk. Although a member who is not present for the organizational meeting may take the oath of office at another time, every member must take, subscribe, and file the oath before he or she begins performing any of the duties of the member's office.

**(c) Selection of [Mayor and] Mayor Pro Tempore.** As the second order of business at the organizational meeting, the council shall elect from among its members [a mayor and] a mayor pro tempore using the procedures specified in Rule 38. [The mayor shall serve for [a certain term] [at the pleasure of the council]]. The mayor pro tempore shall [likewise] serve at the council's pleasure.

#### **Part V. Types of Meetings**

##### **Rule 9. Regular Meetings**

---

**(a) Regular Meeting Schedule.** The council shall hold a regular meeting on the third Monday of each month, except that if a regular meeting day is a legal holiday, the meeting shall be held on the next business day. The meeting shall be held at 110 West Main Street and begin at 7:00 pm. The council shall adopt a meeting schedule each year consistent with this rule. A copy of the council's current meeting schedule shall be filed with the city clerk and posted on the Town's website].

**(b) Change to Meeting Schedule.** Notwithstanding paragraph (a) of this rule, the council may amend its regular meeting schedule to add or delete meetings or to change the date, time, or location of one or more meetings on the schedule. The amended schedule shall be filed with the city clerk at least seven (7) calendar days before the day of the first meeting held pursuant to the revised schedule [and posted on the city's website].

##### **Rule 10. Special Meetings**

---

**(a) Calling Special Meetings.** A special meeting of the council may be called by the mayor, the mayor pro tempore, or any two council members. A special meeting may also be called by vote of the council in open session during a regular meeting or another duly called special meeting.

**(b) Notice to the Public.** At least forty-eight hours before a special meeting of the council, notice of

the date, time, place, and purpose of the meeting shall be (1) posted on the council's principal bulletin board or, if the council has no such board, at the door of the council's usual meeting room and (2) delivered, e-mailed, or mailed to each newspaper, wire service, radio station, television station, and person who has filed a written request for notice with the city clerk. Furthermore, if the council has a website maintained by at least one city employee, notice of the special meeting's date, time, place, and purpose shall be posted on the website in advance of the meeting.

**(c) Notice to Members.**

- (1) *Meeting called by the mayor, the mayor pro tempore, or any two council members.* At least forty-eight hours before a special meeting called by the mayor, the mayor pro tempore, or any two council members, written notice of the meeting stating its date, time, and place, as well as the subjects to be considered, shall be delivered to the mayor and each council member or left at his or her usual dwelling place.
- (2) *Meeting called by vote of the council in open session.* When a special meeting is called by vote of the council in open session during a regular meeting or another duly called special meeting, the motion or resolution calling the special meeting shall state the meeting's date, time, place, and purpose. [Written notice of the special meeting's date, time, place, and purpose shall be mailed or delivered at least forty-eight hours before the meeting to each council member not present for the meeting at which the special meeting was called and to the mayor if he or she was not present at that meeting.]

**(d) Transacting Other Business.** Unless all members are present or any absent member has signed a written waiver of notice, only those items of business specified in the notice to council members may be taken up at a special meeting. [Even when all members are present or any absent member has signed a waiver, the council may take up an item of business not covered by the notice only if the council first determines in good faith that the item must be discussed or acted upon immediately.]

**Rule 11. Emergency Meetings**

---

**(a) Grounds for Emergency Meeting.** Emergency meetings of the city council may be called only to address generally unexpected circumstances demanding the council's immediate attention.

**(b) Calling Emergency Meetings.** There are two methods by which an emergency meeting of the council may be called.

- (1) The mayor, the mayor pro tempore, or any two members of the council may at any time call an emergency council meeting by signing a written notice stating the date, time, and place of the meeting and the subjects to be considered. The notice shall be delivered to the mayor and each council member or left at his or her usual dwelling place at least six hours before the meeting.
- (2) An emergency meeting may be held when the mayor and all members of the council are present and consent thereto, or when any absent member has signed a written waiver of notice.

**(c) Notice to Media of Emergency Meetings.** Notice of an emergency meeting shall be given to each local newspaper, local wire service, local radio station, and local television station that has filed a written request with the city clerk for notice of emergency meetings. To be valid, the request must

include the newspaper's, wire service's, or station's telephone number. Notice may be given by telephone, e-mail, or the same method used to notify council members. Notice must be provided immediately after council members have been notified and at the expense of the party notified.

**(d) Transaction of Other Business Prohibited.** Only business connected with the emergency may be considered at an emergency meeting.

#### **Rule 12. Recessed Meetings**

---

**(a) Calling Recessed Meetings.** When conducting a properly called regular, special, or emergency meeting, the council may recess the meeting to another date, time, or place by a procedural motion made and adopted, as provided in Rule 31, Motion 3, in open session. The motion must state the time (including the date, if the meeting will resume on a different day) and place at which the meeting will reconvene.

**(b) Notice of Recessed Meetings.** If the council has a website maintained by one or more city employees, notice of the recessed meeting's date, time, and place must appear on the webpage prior to the meeting. No further notice of a properly called recessed meeting is required.

#### **Part VI. Agenda**

#### **Rule 13. Agenda**

---

**(a) Draft Agenda.**

- (1) *Preparation.* The [city manager/administrator] [city clerk] shall prepare a draft agenda in advance of each meeting of the city council.
- (2) *Requesting placement of items on draft agenda.* For a regular meeting, a request to have an item of business placed on the draft agenda must be received by the [city manager/administrator] [city clerk] at least [two] working days before the date of the meeting. The [city manager/administrator] [city clerk] must place an item on the draft agenda in response to a council member's timely request.
- (3) *Supplemental information/materials.* If the council is expected to consider a proposed ordinance or ordinance amendment, a copy of the proposed ordinance or amendment shall be attached to the draft agenda. [An agenda package shall be prepared that includes, for each item of business listed on the draft agenda, as much background information on the topic as is available and feasible to provide.]
- (4) *Delivery to council members.* Each council member shall receive a hard or electronic copy of the draft agenda [and the agenda package]. [Except in the case of an emergency meeting, the agenda [and agenda package] shall be furnished to each member at least [twenty-four hours] before the meeting.]
- (5) *Public inspection.* The draft agenda [and agenda package] shall be available to the public when the document[s] [is/are] ready to be, or [has/have] been, circulated.

**(b) Adoption of the Agenda.**

- (1) *Adoption.* As its first order of business at each meeting, the council shall review the draft agenda, make whatever revisions it deems appropriate, and adopt a formal agenda for the meeting.
- (2) *Amending the agenda.* Both before and after it adopts the agenda, the council may add or subtract agenda items by majority vote of the members present and voting, except that
  1. the council may not add to the items stated in the notice of a special meeting unless the requirements in Rule 10(d) are satisfied and
  2. only business connected with the emergency may be considered at an emergency meeting.
- (3) *Designation of items "For Discussion and Possible Action."* The council may designate an agenda item "for discussion and possible action." The designation signifies that the council intends to discuss the item and may, if it so chooses, take action on the item following the discussion.

**(c) Consent Agenda.** The council may designate part of an agenda for a regular meeting as the *consent agenda*. Items may be placed on the consent agenda by the person(s) charged with preparing the draft agenda if the items are judged to be noncontroversial and routine. Prior to the council's adoption of the meeting agenda under subparagraph (b)(1) of this rule, the request of any member to have an item moved from the consent agenda to unfinished business must be honored by the council. All items on the consent agenda must be voted on and adopted by a single motion, with the minutes reflecting the motion and vote for each item.

**(d) Informal Discussion of Agenda Items.** The council may informally discuss an agenda item even when no motion regarding that item is pending.

#### **Rule 14. Acting by Reference to Agenda or Other Document**

---

The council shall not deliberate, vote, or otherwise take action on any matter by reference to the agenda or any other document with the intention of preventing persons in attendance from understanding what action is being considered or undertaken. The council may deliberate and vote by reference to the agenda or any item on the agenda, including the consent agenda, provided copies of the agenda are available for public inspection at the meeting and are sufficiently worded to enable the public to understand what is being deliberated or acted upon.

#### **Rule 15. Agenda Items from Members of the Public**

---

If a member of the public wishes to request that the council include an item on its regular meeting agenda, he or she must submit the request to the [city clerk/city manager/administrator] by the deadline specified in Rule 13(a)(2). The council is not obligated to place an item on the agenda merely because such a request has been received.

#### **Rule 16. Order of Business**

---

Items shall be placed on a regular meeting agenda according to the order of business. The usual order of business for each regular meeting shall be as follows:

1. Call to Order

2. Moment of Silence
3. Pledge of Allegiance to the Flag
4. ~~Statement of Disclosure/Conflict of Interest Statement~~
5. ~~4.~~
6. ~~5.~~ Agenda Adjustments and Approval
7. ~~6.~~ Consent Agenda
8. ~~7.~~ **Public Hearings**
9. ~~8.~~ **PUBLIC HEARINGS: To Begin at 7:30 p.m.** Proclamations/Presentations
10. ~~9.~~ Regular Agenda
11. ~~10.~~ Comments from the Public
12. ~~11.~~ Council Comments
13. ~~12.~~ Closed Session (If Required)
14. ~~13.~~ Adjournment

*Without objection, the mayor may call agenda items in any order most convenient for the dispatch of business.*

*\*STATEMENT OF DISCLOSURE (To be read by the ~~City~~ Mayor)*

*~~Elizabeth City~~ Town of Biscoe Code of Ethics provides that public officials and employees be independent, impartial and responsible to the public; that governmental decisions and policy be made in proper channels of the governmental structure; that public office not be used for personal gain; and that the public have confidence in the integrity of its government. In recognition of these goals and in keeping with the ethical standards of conduct for ~~city~~ town public officials and its employees, disclosure of interest in legislative action must be stated for the public record, as per ~~City of Elizabeth City~~ Town of Biscoe Town Code of Ordinances Section 2-113. The mayor or any member of the ~~city~~ town council who has an interest, as defined in Section 2-111 of the ~~City of Elizabeth City~~ Town of Biscoe Town Code of Ordinances, in any official act or action before the council shall publicly disclose on the record of the council the nature and extent of such interest, and shall withdraw from any consideration of the matter if excused by the council pursuant to G.S. 160A-75.*

## **Part VII. Role of the Presiding Officer**

### **Rule 17. The Mayor**

**(a) Presiding Officer.** When present, the mayor shall preside at meetings of the council.

**(b) Right to Vote.** The mayor [may vote only when an equal number of affirmative and negative votes have been cast] [votes on the same basis as other council members, though in no event may the mayor break a tie on a motion on which he or she has already voted].

**(c) Recognition of Members.** A member must be recognized by the mayor (or other presiding officer) in order to address the council, but recognition is not necessary for an appeal pursuant to Rule 31, Motion 1.

**(d) Powers as Presiding Officer.** As presiding officer, the mayor is to enforce these rules and maintain order and decorum during council meetings. To that end, the mayor may

- (1) Rule on points of parliamentary procedure, to include ruling out of order any motion clearly offered for obstructive or dilatory purposes;
- (2) Determine whether a member or other speaker has gone beyond reasonable standards of courtesy in his or her remarks and entertain and rule on objections from other members on this ground;
- (3) Entertain and answer questions of parliamentary procedure;
- (4) Call a brief recess at any time; and
- (5) Adjourn in an emergency.

**(e) Appeals of Procedural Rulings.** A member may appeal a decision made or answer given by the mayor under subparagraph (d)(1), (2), or (3) in accordance with Rule 31, Motion 1.

#### **Rule 18. The Mayor Pro Tempore**

---

**(a) Presiding in Mayor's Absence.** When present, the mayor pro tempore shall preside over council meetings in the mayor's absence with all the powers specified in Rule 17(d).

**(b) Delegation of Mayor's Powers/Duties.** In the mayor's absence, the council may confer on the mayor pro tempore any of the mayor's powers and duties. Likewise, if the mayor becomes physically or mentally unable to perform the duties of his or her office, the council may by unanimous vote declare the mayor incapacitated and confer any of the mayor's powers and duties on the mayor pro tempore. When the mayor announces that he or she is no longer incapacitated, and a majority of the council concurs, the mayor shall resume the exercise of his or her powers and duties.

**(c) Duty to Vote.** Even when presiding over a council meeting, the mayor pro tempore has the same duty as other members to vote on all questions unless he or she has been excused from voting on a matter in accordance with Rule 28.

#### **Rule 19. Other Presiding Officer**

---

If both the mayor and mayor pro tempore are absent, the council may elect from among its members a temporary presiding officer to chair the meeting. While serving as temporary presiding officer, a member has the powers listed in Rule 17(d). Service as a temporary presiding officer does not relieve a member of the duty to vote on all questions unless excused from voting pursuant to Rule 28.

#### **Rule 20. When the Presiding Officer Is Active in Debate**

---

If the mayor becomes active in debate on a particular proposal, he or she [may] [must] have the mayor pro tempore preside during the council's consideration of the matter. If the mayor pro tempore is absent or is also actively debating the matter, the mayor [may] [must] designate another member to preside until the matter is concluded. Similarly, if the mayor pro tempore or a temporary presiding officer is presiding and takes an active part in debating a topic, he or she [may] [must] designate another council member to preside temporarily.



## **Part VIII. Motions and Voting**

### **Rule 21. Action by the Council**

---

Except as otherwise provided in these rules, the council shall act by motion. Any member may make a motion, [not] including the mayor.

### **Rule 22. Second Not Required**

---

No second is required on any motion.

### **Rule 23. One Motion at a Time**

---

A member may make only one motion at a time.

### **Rule 24. Withdrawal of Motion**

---

The member who introduces a motion may withdraw the motion unless the motion has been amended or the presiding officer has put the motion to a vote.

### **Rule 25. Debate**

---

The presiding officer shall state the motion and then open the floor to debate, presiding over the debate according to the principles listed below.

1. • The maker of the motion is entitled to speak first.
2. • A member who has not spoken on the issue shall be recognized before a member who has already spoken.
3. • To the extent practicable, the debate shall alternate between proponents and opponents of the measure.
4. • [No member may speak more than twice on the same substantive motion. A member's first speech on a substantive motion shall be limited to [10] minutes, and any second speech on the same motion shall be limited to [five] minutes. The same rules apply to debate on a procedural motion, except that a member's first speech shall not exceed [five] minutes, and any second speech shall be limited to [two] minutes.]

### **Rule 26. Adoption by Majority Vote**

---

A motion is adopted if supported by a simple majority of the votes cast, a quorum being present, except when a larger majority is required by these rules or state law.

### **Rule 27. Changing a Vote**

---

A member may change his or her vote on a motion at any time before the presiding officer announces whether the motion has passed or failed. Once the presiding officer announces the result, a member may not change his or her vote without the unanimous consent of the remaining members present. A member's request for unanimous consent to change a vote is not in order unless made immediately following the presiding officer's announcement of the result.

### **Rule 28. Duty to Vote**

---

**(a) Duty to Vote.** Every council member must vote except when excused from voting as provided by this rule.

**(b) Grounds for Excusal.** A member may be excused from voting on a matter involving the member's own financial interest or official conduct, though not if the proposal in question is one to alter the compensation or allowances paid to council members. Members may also be excused from voting when prohibited from voting under G.S. 14-234 (contract providing direct benefit to member), G.S. 160A-381(d) (legislative zoning decision likely to have a direct, substantial, and readily identifiable financial impact on member), or G.S. 160A-388(e)(2) (member's participation in quasi-judicial decision would violate affected person's right to an impartial decision maker). [Questions about whether a basis for excusal exists should be directed to the city attorney.]

**(c) Procedure for Excusal.**

- (1) *At member's request.* Upon being recognized at a duly called meeting of the council, a member who wishes to be excused from voting shall so inform the presiding officer, who must then submit the matter to a vote of the remaining members present. If a majority of the remaining members present vote to excuse the member, the member is excused from voting on the matter.
- (2) *On council's initiative.* Even when a member has not asked to be excused from voting on a matter, a majority of the remaining council members present may by motion and vote excuse the member from voting if grounds for doing so exist under paragraph (b).

**(d) Consequence of Non-Excused Failure to Vote.** Except as specified in paragraph (e), if a member who has not been excused from voting fails to vote on a matter, the member's failure to vote shall be recorded as an affirmative vote, provided

- (1) the member is physically present in the council chamber or
- (2) the member has physically withdrawn from the meeting without being excused by majority vote of the remaining members present.

**(e) Failure to Vote on Certain Zoning Matters.** A member's unexcused failure to vote shall not be recorded as an affirmative vote if the motion concerns a proposal to amend, supplement, or repeal a zoning ordinance. Instead, the member's unexcused failure to vote shall be recorded as an abstention.

**(f) Mayor's Duty to Vote.** The provisions of this rule apply to the mayor.

**Rule 29. Voting by Written Ballot**

---

**(a) Secret Ballots Prohibited.** The council may not vote by secret ballot.

**(b) Rules for Written Ballots.** The council may decide by majority vote or unanimous consent to vote on a motion by written ballot. Each member must sign his or her ballot, and the minutes must record how each member voted by name. The ballots must be made available for public inspection in the city clerk's office immediately following the meeting at which the vote took place and remain there until the minutes of that meeting are approved, at which time the ballots may be destroyed.

**Rule 30. Substantive Motions**

---

A substantive motion is not in order if made while another motion is pending. Once the council disposes of a substantive motion, it may not take up a motion that presents essentially the same

issue at the same meeting, unless it first adopts a motion to reconsider pursuant to Rule 31, Motion 14.

### **Rule 31. Procedural Motions**

---

**(a) Certain Motions Allowed.** The council may consider only those procedural motions listed in this rule. Unless otherwise noted, each procedural motion may be debated and amended and requires a majority of votes cast, a quorum being present, for adoption.

**(b) Priority of Motions.** The procedural motions set out in this paragraph are listed in order of priority. A procedural motion is not in order so long as another procedural motion of higher priority is pending, except that

- • any procedural motion other than an appeal under Motion 1 is subject to amendment as provided in Motion 12, and
- • a motion to call the question (end debate) may be made with regard to any procedural motion in accordance with Motion 9.

When several procedural motions are pending, voting must begin with the procedural motion highest in priority, provided that a motion to amend or end debate on the highest priority motion must be voted on first.

**Motion 1. To Appeal a Ruling of the Presiding Officer.** Any member may appeal the presiding officer's ruling on whether a motion is in order or on whether a speaker has violated reasonable standards of courtesy. The presiding officer's response to a question of parliamentary procedure may also be appealed by any member. An appeal is in order immediately after the disputed ruling or parliamentary response and at no other time. The member who moves to appeal need not be recognized by the presiding officer, and if timely made, the motion may not be ruled out of order.

**Motion 2. To Adjourn.** This motion may be used to close a meeting. It is not in order if the council is in closed session.

**Motion 3. To Recess to a Time and Place Certain.** This motion may be used to call a recessed meeting as permitted under Rule 12. The motion must state the time (including the date, if the meeting will reconvene on a different day) and place at which the meeting will resume. The motion is not in order if the council is in closed session.

**Motion 4. To Take a Brief Recess.**

**Motion 5. To Follow the Agenda.** This motion must be made at the time an item of business that deviates from the agenda is proposed; otherwise, the motion is out of order as to that item.

**Motion 6. To Suspend the Rules.** To be adopted, a motion to suspend the rules must receive affirmative votes equal to at least two-thirds of the council's actual membership, excluding vacant seats and not counting the mayor if the mayor votes only in case of a tie. The council may not suspend provisions in these rules that are required under state law.

**Motion 7. To Divide a Complex Motion.** This motion is in order whenever a member wishes to consider and vote on parts of a complex motion separately. The member who makes this motion must specify how the complex motion will be divided.

**Motion 8. To Defer Consideration.** The council may defer its consideration of a substantive motion, and any proposed amendments thereto, to an unspecified time. A motion that has been deferred expires unless the council votes to revive it pursuant to Motion 13 within [100] days of deferral. A new motion having the same effect as a deferred motion may not be introduced until the latter has expired.

**Motion 9. To End Debate (Call the Previous Question).** If adopted, this motion terminates debate on a pending motion, thereby bringing it to an immediate vote. This motion is not in order until every member has had an opportunity to speak once on the pending motion.

**Motion 10. To Postpone to a Certain Time.** This motion may be employed to delay the council's consideration of a substantive motion, and any proposed amendments thereto, until a designated day, meeting, or hour. During the period of postponement, the council may not take up a new motion raising essentially the same issue without first suspending its rules pursuant to Motion 6.

**Motion 11. To Refer a Motion to a Committee.** The council may vote to refer a substantive motion to a committee for study and recommendations. While the substantive motion is pending before the committee, the council may not take up a new motion raising essentially the same issue without first suspending its rules pursuant to Motion 6. If the committee fails to report on the motion within [60] days of the referral date, the council must take up the motion if asked to do so by the member who introduced it.

**Motion 12. To Amend.**

**(a) Germaneness.** A motion to amend must concern the same subject matter as the motion it seeks to alter.

**(b) Limit on Number of Motions to Amend.** When a motion to amend is under consideration, a motion to amend the amendment may be made; however, no more than one motion to amend and one motion to amend the amendment may be pending at the same time.

**(c) Amendments to Ordinances.** Any amendment to a proposed ordinance must be reduced to writing before the vote on the amendment.

**Motion 13. To Revive Consideration.** The council may vote to revive consideration of any substantive motion that has been deferred pursuant to Motion 8, provided it does so within [100] days of its vote to defer consideration.

**Motion 14. To Reconsider.** The council may vote to reconsider its action on a matter, provided the motion to reconsider is made (a) at the same meeting during which the

action to be reconsidered was taken and (b) by a member who voted with the prevailing side. For purposes of this motion, “the same meeting” includes any continuation of a meeting through a motion to recess to a certain time and place (Motion 3). The motion is not in order if it interrupts the council’s deliberation on a pending matter.

**Motion 15. To Rescind.** The council may vote to rescind an action taken at a prior meeting provided rescission is not forbidden by law.

**Motion 16. To Prevent Reintroduction for [Six] Months.** This motion may be used to prevent the reintroduction of a failed substantive motion for a time, but it is in order only when made immediately following the substantive motion’s defeat. To be adopted, this motion must receive votes equal to at least two-thirds of the council’s actual membership, excluding vacant seats and not counting the mayor, unless the mayor may vote on all questions. If this motion is adopted, the ban on reintroduction remains in effect for [six] months or until the council’s next organizational meeting, whichever occurs first.

## **Part IX. Ordinances and Contracts**

### **Rule 32. Introduction of Ordinances**

---

For purposes of these rules, the “date of introduction” for a proposed ordinance is the date on which the council first votes on the proposed ordinance’s subject matter. [The council votes on the subject matter of a proposed ordinance when it votes on whether to adopt or make changes to the proposed ordinance.]

### **Rule 33. Adoption, Amendment, and Repeal of Ordinances**

---

#### **(a) Adoption of Ordinances.**

- (1) *Proposed ordinances to be in writing.* No proposed ordinance shall be adopted unless it has been reduced to writing and distributed to members before a vote on adoption is taken.
- (2) *Adoption on date of introduction.* To be approved on the date of introduction, a proposed ordinance or any action having the effect of an ordinance must receive affirmative votes equal to at least two-thirds of the council’s actual membership, excluding vacant seats and not counting the mayor, unless the mayor has the right to vote on all questions before the council.
- (3) *Adoption after date of introduction.* To be approved after the date of introduction, a proposed ordinance or any action having the effect of an ordinance must receive affirmative votes equal to at least a majority of all council members not excused from voting on the matter. In calculating the number of affirmative votes necessary for approval, the council shall count the mayor if he or she votes on all questions. If the mayor votes only in the case of tie, the mayor’s vote counts if there is an equal division.

**(b) Amendment and Repeal of Ordinances.** The same voting requirements that govern the adoption of proposed ordinances also apply to the amendment or repeal of an ordinance.

#### **Rule 34. Adoption of the Budget Ordinance**

---

**(a) Special Rules for the Adoption or Amendment of the Budget Ordinance.** Notwithstanding any provision in the city charter, general law, or local act,

- (1) the council may adopt or amend the budget ordinance at a regular or special meeting of the council by a simple majority of those members present and voting, a quorum being present;
- (2) no action taken with respect to the adoption or amendment of the budget ordinance need be published or is subject to any other procedural requirement governing the adoption of ordinances or resolutions by the council; and
- (3) the adoption or amendment of the budget ordinance and the levy of taxes in the budget ordinance are not subject to the provisions of any city charter or local act concerning initiative or referendum.

**(b) Notice Requirements for Budget Meetings.** During the period beginning with the submission of the budget to the council and ending with the adoption of the budget ordinance, the council may hold any special meetings that may be necessary to complete its work on the budget ordinance. Except for the notice requirements of the open meetings law, which continue to apply, no provision of law concerning the call of special meetings applies during that period so long as

- • each member of the board has actual notice of each special meeting called for the purpose of considering the budget and
- • no business other than consideration of the budget is taken up.

**(c) No Authority for Closed Sessions.** This rule shall not be construed to authorize the council to hold closed sessions on any basis other than the grounds set out in Rule 5.

#### **Rule 35. Approval of Contracts and Authorization of Expenditures**

---

**(a) Contracts to be in Writing.** No contract shall be approved or ratified by the city council unless it has been reduced to writing at the time of the council's vote.

**(b) Approval of Contracts.** To be approved or ratified, a contract must receive affirmative votes equal to at least a majority of all council members not excused from voting on the contract, including the mayor's vote in the event of a tie.

**(c) Authorization of Expenditure of Public Funds.** The same vote necessary to approve or ratify a contract is required for the council to authorize the expenditure of public funds, except when the expenditure is authorized pursuant to Rule 34.

#### **Part X. Public Hearings and Comment Periods**

##### **Rule 36. Public Hearings**

---

**(a) Calling Public Hearings.** In addition to holding public hearings required by law, the council may hold any public hearings it deems advisable. The council may schedule hearings or delegate that responsibility to city staff members, as appropriate, except when state law directs the council itself to call the hearing. If the council delegates scheduling authority, it must provide adequate guidance to assist staff members in exercising that authority.

**(b) Public Hearing Locations.** Public hearings may be held anywhere within the city or within the county where the city is located.

**(c) Rules for Public Hearings.** The council may adopt reasonable rules for public hearings that, among other things,

- • fix the maximum time allotted to each speaker,
- • provide for the designation of spokespersons for groups of persons supporting or opposing the same positions,
- • provide for the selection of delegates from groups of persons supporting or opposing the same positions when the number of persons wishing to attend the hearing exceeds the capacity of the hall (so long as arrangements are made, in the case of a hearing subject to the open meetings law, for those excluded from the hall to listen to the hearing), and
- • provide for the maintenance of order and decorum in the conduct of the hearing.

**(d) Notice of Public Hearings.** Any public hearing at which a majority of the council is present shall be considered part of a regular or special meeting. Consequently, the relevant notice and related requirements of the open meetings law, as set out in Rules 9 through 12, apply to such hearings. Some statutes mandate additional notice for particular types of hearings, and such notice must be provided together with notice of the meeting during which the hearing will take place.

**(e) Continuing Public Hearings.** The council may continue any public hearing without further advertisement to a time and place certain, provided the time (including the date, if the hearing will resume on a different day) and place of the continued hearing are announced in open session. Except for hearings conducted pursuant to paragraph (g), if a quorum of the council is not present for a properly scheduled public hearing, the hearing must be continued until the council's next regular meeting without further advertisement.

**(f) Conduct of Public Hearings.** At the time appointed for the hearing, the mayor shall call the hearing to order and proceed to allow public input in accordance with any rules adopted by the council for the hearing. Unless the council extends the hearing, when the time allotted for the hearing expires, or when no one wishes to speak who has not done so, the mayor shall [declare the hearing closed] [entertain a motion to close the hearing], and the council shall resume the regular order of business.

**(g) Public Hearings by Less Than a Majority of Council Members.** Nothing in this rule prevents the council from appointing a member or members to hold a public hearing on the council's behalf, except when state law requires that the council itself conduct the hearing.

#### **Rule 37. Public Comment Periods**

---

**(a) Frequency of Public Comment Periods.** The council must provide at least one opportunity for public comment each month at a regular meeting, except that the council need not offer a public comment period during any month in which it does not hold a regular meeting.

**(b) Rules for Public Comment Periods.** The council may adopt reasonable rules for public comment periods that, among other things,

- • fix the maximum time allotted to each speaker,
- • provide for the designation of spokespersons for groups supporting or opposing the same positions,
- • provide for the selection of delegates from groups supporting or opposing the same positions when the number of persons wishing to attend the public comment period exceeds the capacity of the hall (so long as arrangements are made for those excluded from the hall to listen to the hearing), and
- • provide for the maintenance of order and decorum in the conduct of the hearing.

**(c) Content-Based Restrictions Generally Prohibited.** The council may not restrict speakers based on subject matter, as long as their comments pertain to subjects within the council's real or apparent jurisdiction.

## **Part XI. Appointments and Appointed Bodies**

### **Rule 38. Appointments**

---

**(a) Appointments in Open Session.** The council must consider and make any appointment to another body or, in the event of a vacancy on the council, to its own membership in open session.

**(b) Nomination and Voting Procedure.** The council shall use the following procedure to fill a vacancy in the council itself or in any other body over which it has the power of appointment. [The nominating committee shall be called upon to make its report and recommendation(s), if any.] The mayor shall [then] open the floor for nominations, whereupon council members may put forward and debate nominees. When debate ends, the mayor shall call the roll of the members, and each member shall cast a vote for his or her preferred nominee. The voting shall continue until a nominee receives a majority of votes cast during a single balloting.

**(c) Mayor.** The mayor may [not] make nominations [or][and] vote on appointments under this rule.

**(d) Multiple Appointments.** If the council is filling more than one vacancy, each member shall have as many votes in each balloting as there are slots to be filled, and the votes of a majority of the total number of members voting shall be required for each appointment. No member may cast more than one vote for the same candidate for the same vacancy during a single balloting.

**(e) Duty to Vote.** It is the duty of each member to vote for as many appointees as there are appointments to be made, but failure to do so shall not invalidate a member's ballot.

**(f) Vote by Written Ballot.** The council may vote on proposed appointments by written ballot in accordance with Rule 29.

### **Rule 39. Committees and Boards**

---

**(a) Establishment and Appointment.** The council may establish temporary and standing committees, boards, and other bodies to help carry on the work of city government. Unless otherwise provided by law or the council, the power of appointment to such bodies lies with the council.

**(b) Open Meetings Law.** The requirements of the open meetings law apply whenever a majority of an appointed body's members gather in person or simultaneously by electronic means to discuss or conduct official business. They do not apply to meetings solely among the city's professional staff.



**(c) Procedural Rules.** The council may prescribe the procedures by which the city’s appointed bodies operate, subject to any statutory provisions applicable to particular bodies. [In the absence of rules adopted by the council, an appointed body may promulgate its own procedural rules, so long as they are in keeping with any relevant statutory provisions and generally accepted principles of parliamentary procedure.]

**Part XII. Miscellaneous**

**Rule 40. Amendment of the Rules**

---

These rules may be amended at any regular meeting or at any properly called special meeting for which amendment of the rules is one of the meeting’s stated purposes. Any amendment to these rules must be consistent with the city charter, any relevant statutes, and generally accepted principles of parliamentary procedure. To be adopted, a motion to amend these rules must be approved by a majority of the council’s members, excluding vacant seats and counting the mayor only if the mayor may vote on all questions.

**Rule 41. Reference to Robert’s Rules of Order Newly Revised**

---

The council shall refer to *Robert’s Rules of Order Newly Revised* for guidance when confronted with a procedural issue not covered by these rules or state law. Having consulted *Robert’s*, the mayor shall make a ruling on the issue subject to appeal to the council under Rule 31, Motion 1.

Adopted this 12<sup>th</sup> day of August 2019.

---

James E. Blake, Mayor



---

Laura B. Morton, CMC, NCCMC  
Town Clerk

## PERSONAL PROPERTY DISPOSITION POLICY

### PROCEDURE PURPOSE:

To provide a standard procedure for declaring personal property as surplus and disposing of surplus personal property in such a manner as to secure the highest dollar value to the Town of Biscoe.

### POLICY:

---

The purpose of this policy is to dispose of personal property in accordance with North Carolina General Statutes Chapter 160A, Article 12. To prevent conflicts of interest, the Town of Biscoe prohibits the disposition of any surplus property to Council members, as well as any other officials or employees actively involved in the decision-making process for the disposition of the asset. The prohibition also extends to the immediate families of the Council members as well as the family members of the affected officials and employees.

### OVERVIEW:

---

To establish the procedures to notify the Town of Biscoe Manager when personal property is no longer of use in the daily operations of the Town of Biscoe and to establish the steps that are involved in the processing of the disposition of any such personal property.

### PROCEDURES:

---

#### ***Issuance of Request to Surplus Personal Property***

For any furniture, fixture, equipment or vehicle that is no longer of use in the daily operations of the Town of Biscoe, the department head or designee that has budget responsibility for the property should request that the Town of Biscoe Manager approve that the personal property be disposed of by completing a Request To Surplus Personal Property form. The requisition should describe the surplus item (including the year, make and model), the VIN or Serial number, the mileage if the surplus property is a vehicle, and the class code. If there is additional information that would be beneficial to obtaining the highest value for the Town of Biscoe, then that information should be noted in the comments/special considerations section of the form. This includes optional equipment on vehicles such as air conditioning, power windows and door locks, tilt wheel, etc.

### **SURPLUS PERSONAL PROPERTY INFORMATION**

---

*A Surplus Personal Property Information Sheet will be used to:*

- describe the property available for sale or exchange,
- indicate whether or not a bid was accepted,
- to whom it was sold, or with whom exchanged,
- and the amount of money or other consideration received for each sale or exchange.

*The information sheet should include:*

- the property description and the VIN or Serial number (both matching the requisition),
- the placed in-service date,
- the net book value and the estimated fair market value.

(Surplus Personal Property Information Sheet is attached)

Because it is generally unconstitutional for a local government to dispose of property for less than its fair market value, for items not sold at public auction, the Town Clerk should determine the estimated fair market value by using the most independent and verifiable means available. Support for determining the fair market value should be attached to the surplus personal property information sheet. For items sold at public auction, the final sale price is considered the market value of the item sold.

Special consideration must be given to property that was acquired with Grant proceeds. First, the Town Clerk should determine whether or not the property was purchased with Grant proceeds. If it was, then the Town Clerk should determine whether or not the Grant specifies that any funds recouped from its disposition must be returned to the Grantor Agency. If both of these conditions exist, the Town Clerk should mark the "Yes" box on the Surplus Personal Property Information Sheet or otherwise mark "No".

At least annually, the Town of Biscoe will offer the surplus personal property for sale according to the guidelines and limitations for the sale and disposition of personal property as described in G.S. Chapter 160A, Article 12.

Ten (10) days prior to the offer to sale date, the Town Clerk will notify all Department Heads of the details of the surplus property that is available for sale so that if necessary, they can claim the property for use in their department. All surplus property remaining unclaimed after the ten days will be included in the offer to sale.

#### **METHODS OF SALE**

---

The Town of Biscoe adheres to the guidelines and limitations for the sale and disposition of personal property as described in G.S. Chapter 160A, Article 12. Subject to certain limitations the Town of Biscoe may dispose of personal property by:

- (1) Private negotiation and sale;
- (2) Advertisement for sealed bids;
- (3) Negotiated offer, advertisement, and upset bid;
- (4) Public auction (including electronic auction); or
- (5) Exchange

Private negotiation and sale may be used only with respect to personal property valued at less than thirty thousand dollars (\$30,000) for any one item or group of similar items. Personal Property valued at thirty thousand dollars (\$30,000) or more for any one item or group of similar items may be exchanged by private negotiation if the Town of Biscoe receives a full and fair consideration in exchange for its property, or may be sold by any method documented above other than private negotiation and sale, except as permitted in G.S. 160A-277 and G. S. 160A-279.

This policy authorizes the Town of Biscoe Manager to declare surplus any property valued at less than ten thousand dollars (\$10,000) for any one item or group of items, to set its fair market value, and to convey title to the property for the Town of Biscoe in accord with the regulations. The completion of the request to surplus personal property and the surplus personal property information sheet is intended to assure compliance with this policy.

For disposing of personal property valued at ten thousand dollars (\$10,000) or more for any one item or group of items, the Town of Biscoe Council shall at a regular council meeting adopt a resolution authorizing the Town of Biscoe Manager to dispose of the property by one of the methods of sale noted above which is permitted in G.S. 160A-266(a). A notice summarizing the contents of the resolution shall be published once after its adoption, and no sale shall be consummated thereunder until 10 days after its publication.

#### **NOTICE OF SALE**

---

At least annually the Town Clerk will identify the personal property items that are available for sale and initiate the process to dispose of any such surplus personal property by any means which he or she judges reasonably calculated to yield the highest attainable sale price in money or other consideration, including but not limited to the methods of sale provided in Article 12 of N.C. General Statutes Chapter 160A. For items offered by public notice, the notice should describe the property, include an "as is" clause, and provide the location for inspection. The notice should also provide instructions for the bid submission including the deadline, method of bidding (i.e. in person, by mail, fax or phone), and the name and contact information for bid submission. Bids may be accepted at any time after the notice of sale is published. However, the personal property may not be sold sooner than 10 days after the notice has been published. In computing the 10 days, the Town Clerk should not count the day of publication but should compute the last day of the required waiting period. If the last day is a Saturday, Sunday or holiday, it is not counted, and the time period ends at the end of the next day that is not a Saturday, Sunday or holiday.

#### **PROCESSING PUBLISHED BIDS**

---

For surplus property valued at less than ten thousand dollars (\$10,000) for any one item or group of items. All bids will be reviewed by the Town Clerk. If accepted, the Town Clerk will note the successful bidder's name on the information sheet, notify them that they are the successful bidder and arrange for pickup of the personal property. The procedures as outlined in the terms and conditions of sale should be followed by the Town Clerk to complete the sale process. The Town of Biscoe Manager or his designee's signature should be obtained on any applicable title documents at the time of payment in full.

After obtaining the signed title documents, the Town Clerk should attach a copy of the signed title document to the surplus personal property information sheet and enter the sale of the personal property in the fixed asset system, stamp the surplus personal property information sheet posted and file. All records should be retained for a minimum of three (3) years from the date of the sale, as evidenced by the date on the cash receipt voucher or check.

Once posted, if the sold personal property was originally purchased with Grant proceeds and the Grant specified that any proceeds received upon disposition of the property must be returned to the Grantor Agency. The Town Clerk should prepare a disbursement payable to the Grantor for the amount of the sale.

If the highest bid is less than the estimated fair market value, the Town Clerk may reject the offer. If the highest offer is rejected by the Town Clerk or no offers are received for the property, the surplus property may be retained for future sale, disposed of to obtain any reasonably available salvage value, or disposed of as waste material. No surplus property may be donated to any individual or organization except as allowed by the G.S. and approved by resolution of the Town of Biscoe Council.

For surplus property valued at ten thousand dollars (\$10,000) or more for any one item or group of items, bids will be processed in compliance with General Statute Chapter 160A, Article 12 applicable to the method of sale.

This document replaces all previous versions of this policy in their entirety.

Approved this \_\_\_\_\_, of \_\_\_\_\_ 2019.

\_\_\_\_\_  
James E. Blake, Mayor

Attest:

\_\_\_\_\_  
Laura B. Morton, Town Clerk

**Town of Biscoe**  
**Surplus Personal Property Information Sheet**

As provided in the Town of Biscoe's Personal Property Disposition Policy the following are specifics on individual items to be sold at Surplus.

Approved by the Town Manager and/or Town Council on

Description of Property Available
Property Description (VIN or SN):
Placed In Service: _____ Placed Out of Service _____
Net Book Value or Estimated Fair Market Value: _____
Was Property Purchased Thru Grant Funding? <input type="checkbox"/> Yes <input type="checkbox"/> No If Yes, which granting agency: _____ <i>Note: If it was purchased through grant funding it must be returned to the Grantor Agency.</i>

Surplus Bids Received & Bid Amount	
Name Of Bidder	Amount Of Bid

Was is Sold Or Exchanged? <input type="checkbox"/> Sold? <input type="checkbox"/> Exchanged?
--

Bid Award Information	
Winner of Bid & Contact Information	Amount Of Bid

Attachment #3

**TOWN OF BISCOE  
NORTH CAROLINA**

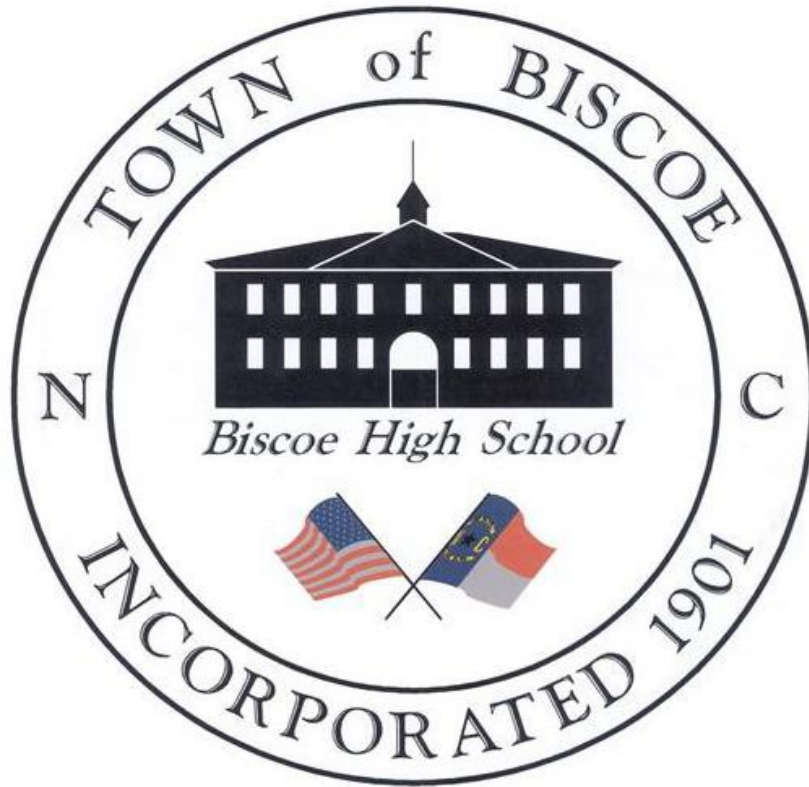

**Personnel Policy**

TOWN OF BISCOE PERSONNEL  
POLICY

BE IT RESOLVED by the Town Board of the Town of Biscoe that the following policies apply to the appointment, classification, benefits, salary, promotion, demotion, dismissal, and conditions of employment of the employees of the Town of Biscoe.

Adopted November 14, 2016  
Amended September 9, 2019

\*The contents of this employee copy vary in font and format from the original text adopted by the Town Board.

Table of Contents

ARTICLE I. GENERAL PROVISIONS

Section 1. Purpose of the Chapter .....5

Section 2. At Will Employment .....5

Section 3. Merit Principles .....5

Section 4. Responsibilities of the Town Board.....5

Section 5. Responsibilities of the Town Manager .....6

Section 6. Application of Policies, Plan, Rules, and Regulations.....7

Section 7. Departmental Rules and Regulations.....7

Section 8. Definitions .....7

ARTICLE II. POSITION CLASSIFICATION PLAN

Section 1. Purpose .....9

Section 2. Composition of the Position Classification Plan.....9

Section 3. Use of the Position Classification Plan .....9

Section 4. Administration of the Position Classification Plan .....10

Section 5. Adoption of the Position Classification Plan .....10

Section 6. Request for Reclassification .....10

ARTICLE III. THE PAY PLAN

Section 1. Definition.....11

Section 2. Administration and Maintenance .....11

Section 3. Cost of Living Adjustments.....11

Section 4. Starting Salaries.....12

Section 5. Trainee Designation and Provisions .....12

Section 6. Probationary Pay Increases .....12

Section 7. Merit Pay.....13

Section 8. Merit Pay Bonus .....13

Section 9. Promotions, Demotions, Transfers, and Reclassifications .....13

Section 10. Salary Effect of Salary Range Revisions.....14

Section 11. Transition to a New Salary Plan.....14

Section 12. Effective Date of Salary Changes.....14

Section 13. Overtime Pay Provisions.....14

Section 14. Call-Back and Stand-By Pay .....15

Section 15. Payroll Deduction.....16

Section 16. Direct Deposit Required.....16

Section 17. Hourly Rate of Pay.....16

Section 18. Longevity Pay .....16

ARTICLE IV. RECRUITMENT AND EMPLOYMENT

Section 1. Equal Employment Opportunity Policy .....19

Section 2. Implementation of Equal Employment Opportunity Policy.....19

Section 3. Recruitment, Selection and Appointment .....19

Section 4. Probationary Period .....20

Section 5. Promotion .....21

Section 6. Demotion.....21

Section 7. Transfer .....21

ARTICLE V. CONDITIONS OF EMPLOYMENT

Section 1. Work Schedule .....22

Section 2. Political Activity.....22

Section 3. Outside Employment.....23



Section 4. Employment of Relatives .....	23
Section 5. Harassment .....	23
Section 6. Acceptance of Gifts and Favors .....	24
Section 7. Performance Evaluation .....	24
Section 8. Safety .....	24
Section 9. Reporting Personal Injuries .....	25
Section 10. Reporting Accidents Involving Town Property/Equipment.....	25
Section 11. Immigration Law Requirements .....	25
Section 12. Use of Town Owned Vehicles.....	25
Section 13. Post-Accident Testing.....	26
Section 14. Uniforms.....	26
ARTICLE VI. EMPLOYEE BENEFITS	
Section 1. Eligibility .....	27
Section 2. Group Health, Hospitalization, Vision and Dental Insurance .....	27
Section 3. Life and Disability Insurance.....	27
Section 4. Other Optional Group Insurance Plans .....	27
Section 5. Retirement .....	27
Section 6. Supplemental Retirement Benefits (401-K) .....	27
Section 7. Social Security .....	28
Section 8. Workers' Compensation.....	28
Section 9. Unemployment Compensation .....	28
Section 10. Education Assistance Program .....	29
Section 11. Flexible Benefits Plan (125 Plan) .....	29
ARTICLE VII. HOLIDAYS AND LEAVES OF ABSENCE	
Section 1. Policy .....	30
Section 2. Leave Pro-rated .....	30
Section 3. Holidays .....	31
Section 4. Holidays: Effect on Other Types of Leave .....	31
Section 5. Holidays: Compensation for Shift Personnel.....	31
Section 6. Annual Leave .....	32
Section 7. Annual Leave: Use by Probationary Employees.....	32
Section 8. Annual Leave: Accrual Rate.....	33
Section 9. Annual Leave: Maximum Accumulation .....	33
Section 10. Annual Leave: Manner of Taking.....	33
Section 11. Annual Leave: Payment upon Separation .....	34
Section 12. Annual Leave: Payment Upon Death .....	34
Section 13. Sick Leave .....	35
Section 14. Sick Leave: Accrual Rate and Accumulation.....	35
Section 15. Sick Leave: Medical Certification.....	36
Section 16. Leave Without Pay .....	37
Section 17. Leave Sharing .....	37
Section 18. Workers' Compensation Leave.....	38
Section 19. Military Leave.....	38
Section 20. Reinstatement Following Military Service. ....	39
Section 21. Civil Leave.....	39
Section 22. Hazardous Weather Conditions .....	39
Section 23. Funeral Leave .....	40
Section 24. Petty Leave/Community Service Leave .....	40
Section 25. Family and Medical Leave .....	41
Section 26. Medical & Family Leave – Certification.....	44

Section 27. FMLA & Leave Without Pay: Retention & Benefit Continuation.....	44
Section 28. Bereavement Leave.....	45
ARTICLE VIII. SEPARATION AND REINSTATEMENT	
Section 1. Types of Separations .....	46
Section 2. Resignation.....	46
Section 3. Reduction in Force.....	46
Section 4. Disability.....	46
Section 5. Voluntary Retirement.....	46
Section 6. Death .....	47
Section 7. Dismissal.....	47
Section 8. Reinstatement.....	47
Section 9. Rehiring .....	47
ARTICLE IX. UNSATISFACTORY JOB PERFORMANCE AND DETRIMENTAL PERSONAL CONDUCT	
Section 1. Disciplinary Action for Unsatisfactory Job Performance.....	48
Section 2. Unsatisfactory Job Performance Defined.....	48
Section 3. Communication and Warning Procedures .....	49
Section 4. Disciplinary Action for Detrimental Personal Conduct.....	49
Section 5. Detrimental Personal Conduct Defined .....	50
Section 6. Disciplinary Conference.....	51
Section 7. Non-Disciplinary Suspension .....	51
ARTICLE X. GRIEVANCE & WHISTLE BLOWING PROCEDURE	
Section 1. Policy .....	52
Section 2. Grievance Defined.....	52
Section 3. Purposes of the Grievance Procedure.....	52
Section 4. Procedure.....	53
Section 5. Grievance & Appeal Procedure for Discrimination .....	54
Section 6. Back Pay Awards.....	54
Section 7. Employee Representation .....	54
Section 8. Whistle Blowing Procedure & Protection .....	55
ARTICLE XI. PERSONNEL RECORDS AND REPORTS	
Section 1. Public Information.....	56
Section 2. Access to Confidential Records .....	56
Section 3. Personnel Actions.....	57
Section 4. Records of Former Employees .....	57
Section 5. Remedies of Employees Objecting to Material in File .....	57
Section 6. Penalties for Permitting Access to Confidential Records .....	57
Section 7. Examining or Copying Material Without Authorization.....	58
Section 8. Destruction of Records Regulated .....	58
ARTICLE XII. IMPLEMENTATION OF POLICIES	
Section 1. Conflicting Policies Repealed.....	59
Section 2. Separability.....	59
Section 3. Effective Date .....	59

## **ARTICLE I. GENERAL PROVISIONS**

### **Section 1. Purpose of the Chapter**

It is the purpose of this policy and the rules and regulations set forth to establish a fair and uniform system of personnel administration for all employees of the Town under the supervision of the Town Manager. This policy is established under authority of Chapter 160A, Article 7, of the General Statutes of North Carolina.

### **Section 2. At Will Employment**

The Town of Biscoe is an "at will" employer. Nothing in this policy creates an employment contract or term between the Town and its employees. No person has the authority to grant any employee any contractual rights of employment.

### **Section 3. Merit Principles**

All appointments and promotions shall be made solely on the basis of merit. All positions requiring the performance of the same duties and fulfillment of the same responsibilities shall be assigned to the same class and the same salary range. No applicant for employment or employee shall be deprived of employment opportunities or otherwise adversely affected as an employee because of such individual's race, color, religion, sex, national origin, political affiliation, non-disqualifying disability or age.

### **Section 4. Responsibilities of the Town Board**

The Town Board shall be responsible for establishing and approving personnel policies, the position classification and pay plan, and it may change the policies and benefits as necessary. The Board also shall make and confirm appointments when so specified by the general statutes.

## **Section 5. Responsibilities of the Town Manager**

The Town Manager shall be responsible to the Town Board for the administration and technical direction of the personnel program. The Town Manager shall appoint, suspend, and remove all Town officers and employees except those elected by the people or whose appointment is otherwise provided for by law. The Town Manager shall ensure that all appointments, dismissals and suspensions are made in accordance with the Town Charter and other policies and procedures spelled out in other Articles in this Chapter.

The Town Manager shall:

- a) Recommend rules and revisions to the personnel system to the Town Board for consideration;
- b) Make changes as necessary to maintain an up to date and accurate position classification system;
- c) Prepare and recommend revisions to the pay plan to the Town Board for approval;
- d) Determine which employees shall be subject to the overtime provisions of Fair Labor Standards Act;
- e) Establish and maintain a roster of all persons and authorized positions in the municipal service, setting forth each position and employee, class title of position, salary, any changes in class title and status, and such data as may be desirable or useful;
- f) Develop and administer such recruiting and retention programs as may be necessary to obtain and retain an adequate supply of competent employees to meet the needs of the Town;
- g) Develop and coordinate training and educational programs for Town employees;
- h) Investigate periodically the operation and effect of the personnel provisions of this chapter; and
- i) Perform such other duties as may be assigned by the Town Board not inconsistent with this Chapter.

## **Section 6. Application of Policies, Plan, Rules, and Regulations**

The personnel policy and all rules and regulations adopted pursuant thereto shall be binding on all Town employees. The Town Manager, Town Attorney, members of the Town Board and advisory boards and commissions will be exempted except in sections where specifically included. An employee violating any of the provisions of this policy shall be subject to appropriate disciplinary action, as well as prosecution under any civil or criminal laws which have been violated.

## **Section 7. Departmental Rules and Regulations**

Due to the personnel and operational requirements of the various departments of the Town, each department is authorized to establish supplemental rules and regulations applicable only to the personnel of that department. All such rules and regulations shall be subject to the approval of the Town Manager, and shall not in any way conflict with the provisions of this Policy, but shall be considered as a supplement to this Chapter. If a conflict arises, the provisions of this Policy shall be followed.

## **Section 8. Definitions**

For the purposes of this chapter, the following words and phrases shall have the meanings respectively ascribed to them by this section:

**Full-time employee:** An employee who is in a position for which an average work week equals at least 40 hours, and continuous employment of at least 12 months, is required by the Town.

**Part-time employee:** An employee who is in a position for which an average work week of at least 20 hours and less than 40 hours and continuous employment of at least 12 months is required by the Town.

**Regular employee:** An employee appointed to a full or part-time position who has successfully completed the designated probationary period.

**Probationary employee:** An employee appointed to a full or part-time position who has not yet successfully completed the designated probationary period.

**Temporary employee:** An employee appointed to a position for which either the average work week required by the Town over the course of a year is less than 20 hours, or continuous employment required by the Town is less than 12 months.

**Trainee:** An employee status when an applicant is hired (or employee promoted) who does not meet all of the requirements for the position. During the duration of a trainee appointment, the employee is on probationary status.

**Contractual:** Employees hired by means of a contract to accomplish a specific job in a specified time frame. These employees are not entitled to any of the available benefits.

**ARTICLE II. POSITION CLASSIFICATION PLAN**  
**(Effective July 1, 2017)**

**Section 1. Purpose**

The position classification plan provides a complete inventory of all authorized and permanent positions in the Town service, and an accurate description and specification for each class of employment. The plan standardizes job titles, each of which is indicative of a definite range of duties and responsibilities.

**Section 2. Composition of the Position Classification Plan**

The classification plan shall consist of:

- a) A grouping of positions in classes which are approximately equal in difficulty and responsibility which call for the same general qualifications, and which can be equitably compensated within the same range of pay under similar working conditions;
- b) class titles descriptive of the work of the class;
- c) written specifications for each class of positions; and
- d) An allocation list showing the class title of each position in the classified service.

**Section 3. Use of the Position Classification Plan**

The classification plan is to be used:

- a) As a guide in recruiting and examining applicants for employment;
- b) In determining lines of promotion and in developing employee training programs;
- c) In determining salary to be paid for various types of work;
- d) In determining personnel service items in departmental budgets; and
- e) In providing uniform job terminology.

**Section 4. Administration of the Position Classification Plan**

The Town Manager shall allocate each position covered by the classification plan to its appropriate class, and shall be responsible for the administration of the position classification plan. The Town Manager shall periodically review portions of the classification plan and make minor revisions to ensure that classifications accurately reflect current job duties and responsibilities. The Town Manager shall also periodically review the entire classification plan and, when needed, recommend major changes to the Town Board.

**Section 5. Adoption of the Position Classification Plan**

The position classification plan shall be adopted by the Town Board and shall be on file with the Town Manager and Town Clerk. Copies shall be available to Town employees for review upon request. New positions shall be established upon recommendation of the Town Manager and approval of the Town Board after which the Town Manager shall either allocate the new position into the appropriate existing class, or amend the position classification plan to establish a new class to which the new position may be allocated.

**Section 6. Request for Reclassification**

Any employee who considers the classification of position which he/she occupies to be improper shall submit a request in writing for reclassification to such employee's immediate supervisor, who shall immediately transmit the request to the Town Manager. Upon receipt of such request, the Town Manager shall study the request, determine the merit of the reclassification, and forward the recommendation to the Town Board for consideration.

**ARTICLE III. THE PAY PLAN**  
**(Effective July 1, 2017)**

**Section 1. Definition**

The pay plan includes the basic Salary Schedule and the "Assignment of Classes to Salary Grades and Ranges" adopted by the Town Board. The salary schedule consists of a minimum and maximum salary for each job classification approved by the Town Board. Salary increases within the pay range shall be based on criteria established by the Town Manager and approved by the Town Board.

**Section 2. Administration and Maintenance**

The Town Manager shall be responsible for the administration and maintenance of the pay plan. All employees covered by the pay plan shall be paid at a rate listed within the salary range established for the respective position classification, except for employees in trainee status or employees whose existing salaries are above the established maximum rate following transition to a new pay plan.

The pay plan is intended to provide equitable compensation for all positions, reflecting differences in the duties and responsibilities, the comparable rates of pay for positions in public employment in the area, changes in the cost of living, the financial conditions of the Town, and other factors. To this end, from time to time the Town Manager shall make comparative studies of all factors affecting the level of salary ranges and may make minor adjustments in the allocation of positions to salary grades. When major adjustments encompassing numerous positions are needed, or when a general adjustment is needed to the pay plan, the Town Manager shall recommend such changes in salary ranges as appear to be warranted to the Town Board. The Town Board shall adopt the "Assignment of Classes to Salary Grades and Ranges," including any minor adjustments made by the Town Manager during the previous budget year, annually as part of the budget process.

**Section 3. Cost of Living Adjustments**

Annually the Town Board will consider and adjust the Town's pay plan in accordance with the amount of consumer price index, depending on the availability of funds. The salary schedule will be adjusted by the approved cost of living increase. Employees' salaries will be adjusted by the amount of the approved pay plan adjustment for the cost of living.

**Section 4. Starting Salaries**

All persons employed in positions approved in the position classification plan normally shall be employed at the minimum salary for the classification in which they are employed; however, on the recommendation of the Department Head, and support of the Town Manager, employee salaries may be approved above the minimum. Reasons for hiring above the minimum include education and experience qualifications of the applicant, a shortage of qualified applicants, and the refusal of qualified applicants to accept employment at the minimum. Pay for part-time or temporary status will be paid a prorated amount determined by converting the established salary range to an hourly rate.

**Section 5. Trainee Designation and Provisions**

Applicants being considered for employment or Town employees who do not meet all of the requirements for the position for which they are being considered may be hired, promoted, demoted, or transferred by the Town Manager to a "trainee" status. In such cases, a plan for training, including a time schedule, must be prepared by the Department Head or Town Manager. An employee shall remain at the trainee salary level until the Department Head certifies that the trainee is qualified to assume full responsibilities of the position and the Town Manager approves the certifications. The Department Head



shall review the progress of each employee in a trainee status every six months or more frequently as necessary to determine when the trainee is qualified to assume full responsibilities of the position. "Trainee" salaries may be no more than two grades below the minimum salary established for the position for which the person is being trained. A new employee designated as "trainee" shall be regarded as a probationary employee.

If the training is not successfully completed as planned, the trainee shall be transferred, demoted, or dismissed. If the training is successfully completed, the employee shall be paid at least at the minimum rate established for the position for which the employee was trained.

#### **Section 6. Probationary Pay Increases**

Employees hired or promoted into the Minimum Rate of the pay range shall receive a salary increase within the salary range upon successful completion of the probationary period. Employees serving a twelve month probationary period are eligible for consideration for this pay increase after six months of successful employment.

#### **Section 7. Merit Pay**

Annually the Town Board will consider funding a system of Merit Pay proposed by the Town Manager. Upward movement within the established salary range for an employee is not automatic but rather based on specific performance related reasons. Employees may be considered for advancement within the established salary range based on the quality of their overall performance on an annual basis. Procedures for determining performance levels and performance pay increases shall be established in procedures approved by the Town Manager.

#### **Section 8. Merit Pay Bonus**

When funded by the Town Board, employees who are at the top step of the salary range for their position classification are eligible to be considered for a merit bonus at their regular performance evaluation time. Merit bonuses shall be awarded based upon the performance of the employee as described in the performance evaluation and shall be the same percentage of annual salary as employees within the salary range with the same performance level. Merit bonuses do not become part of the base pay and shall be awarded in a lump sum payment.

#### **Section 9. Promotions, Demotions, Transfers, and Reclassifications**

**Promotions.** When an employee is promoted, the employee's salary shall normally be advanced to the minimum level of the new position, or to a salary which provides an increase of at least approximately 5% over the employee's salary before the promotion, provided, however, that the new salary may not exceed the maximum rate of the new salary range. The purpose of the promotion pay increase is to recognize and compensate the employee for taking on increased responsibility.

**Demotions.** When an employee is demoted to a position for which qualified, the salary shall be set at the rate in the lower pay range which provides the smallest decrease in pay if action is not for cause. If the current salary is within the new range, the employee's salary may be retained at the previous rate. If the demotion is for cause, the salary shall be decreased at least approximately 5%, or to the maximum of the new range.

**Transfers.** The salary of an employee reassigned to a position in the same class or to a position in a different class within the same salary grade shall not be changed by the reassignment.

Reclassifications. An employee whose position is reclassified to a class having a higher salary range shall receive a pay increase of approximately 5% or an increase to the minimum of the new pay range, whichever is higher. If the position is reclassified to a lower pay range, the employee's salary shall remain the same. If the employee's salary is above the maximum established for the new range, the salary of that employee shall be maintained at the current level until the range is increased above the employee's salary.

#### **Section 10. Salary Effect of Salary Range Revisions**

When a class of positions is assigned to a higher salary range, employees in that class shall receive a pay increase to the corresponding level of the new salary grade. When a class of positions is assigned to a lower salary range, the salaries of employees in that class will remain unchanged. If this assignment to a lower salary range results in an employee being paid at a rate above the maximum step established for the new class, the salary of that employee shall be maintained at that level until such time as the employee's salary range is increased above the employee's current salary.

#### **Section 11. Transition to a New Salary Plan**

The following principles shall govern the transition to a new salary plan:

1. No employee shall receive a salary reduction as a result of the transition to a new salary plan.
2. All employees being paid at a rate lower than the minimum rate established for their respective classes shall have their salaries raised to the new minimum for their classes.
3. All employees being paid at a rate below the maximum rate established for their respective classes shall be paid at a rate listed in the salary schedule; all employees not at a listed rate shall have their salaries raised to a listed rate.
4. All employees being paid at a rate above the maximum rate established for their respective classes shall be maintained at that salary level until such time as the employees' salary range is increased above the employees' current salary.

#### **Section 12. Effective Date of Salary Changes**

Salary changes approved after the first working day of a pay period shall become effective at the beginning of the next pay period or at such specific date as may be provided by procedures approved by the Town Manager.

#### **Section 13. Overtime Pay Provisions**

Employees of the Town can be requested and may be required to work overtime hours as necessitated by the needs of the Town and determined by the Department Head. The Town Manager must approve all overtime.

To the extent that local government jurisdictions are so required, the Town will comply with the Fair Labor Standards Act (FLSA). The Town Manager shall determine which jobs are "non-exempt" and are therefore subject to the Act in areas such as hours of work and work periods, rates of overtime compensation, and other provisions.

Non-exempt employees will be paid at a straight time rate for hours up to the FLSA established limit for their position (usually 40 hours in a 7 day period). Employees in public safety job classes earn overtime based on a 28 day time period; overtime does not occur for personnel in law enforcement until 171 hours are worked.

In determining eligibility for overtime in a work period, only hours actually worked shall be considered; in no event will annual, sick leave, or holidays be included in the computation of hours worked for FLSA purposes.

Whenever practicable, departments will schedule time off on an hour-for-hour basis within the applicable work period for non-exempt employees, instead of paying overtime. When time off within the work period cannot be granted, overtime worked will be given in the form of compensatory time off or paid in accordance with the FLSA.

Compensatory time off will be scheduled for the employee as soon as possible whenever feasible and within 30 days as determined by the Manager. No employee shall be paid for overtime work except upon recommendation of the Manager.

Emergency Situations – non-exempt employees In emergency situations, non-exempt employees will be compensated at their usual overtime rate of time and one half for hours worked in excess of (40) forty hours per week and double time for hours worked on weekends and holidays. Police Officers are paid regular pay for hours worked up to 171 in a 28-day cycle and any hours over 171 are paid at time and one half. Emergency Situations – exempt employees

For exempt employees (including Department Heads) required to work extended hours during an emergency, the Town Council shall compensate for hours worked over and above the regular workweek at their regular hourly rate.

Department Heads are "exempt" for the FLSA and shall work the number of hours necessary to assure the satisfactory performance of their normal duties; compensatory time may be tracked for management purposes but they are not eligible to earn overtime pay or compensatory time.

#### **Section 14. Call-Back and Stand-By Pay**

The Town provides a continuous twenty-four hour a day, seven day a week service to its customers. Therefore, it is necessary for certain employees to respond to any reasonable requests for duty at any hour of the day or night. One of the conditions of employment with the Town is the acceptance of a share of the responsibility for continuous service, in accordance with the nature of each job position. If an employee fails to respond to reasonable calls for emergency service, either special or routine, the employee shall be subject to disciplinary action up to and including dismissal.

Call-back. Non-exempt employees will be guaranteed a minimum payment of one hour of wages for being called back to work outside of normal working hours when not on stand-by. "Call-back" provisions do not apply to previously scheduled overtime work (scheduled one or more days in advance).

Stand-by. Non-exempt employees required to be on "stand-by" duty will be paid Stand-by time is defined as that time when an employee must remain near an established telephone or otherwise substantially restrict personal activities in order to be ready to respond when called. Or in cases where Public Works Employees will be checking pumps on weekends. Pay will be as follows:

- \$100 per Weekend
- \$150 per Holiday Weekend

**Section 15. Payroll Deduction**

Deductions shall be made from each employee's salary, as required by law. Additional deductions may be made upon the request of the employee on determination by the Town Manager as to capability of payroll equipment and appropriateness of the deduction.

Required deductions include: Federal Income Tax; State Income Tax; Social Security (FICA); and Local Government Retirement.

**Section 16. Direct Deposit Required**

In accordance with State Law, the Town Manager may dictate that the Town compensates employees by direct deposit, ACH, or other electronic means.

**Section 17. Hourly Rate of Pay**

Employees working in a part-time or temporary capacity with the same duties as full-time employees will work at a rate in the same salary range as the full-time employees working 40 hours per week.

**Section 18. Longevity Pay (Effective July 1, 2017)**

Full-time regular employees of the Town are compensated for years of service by payment of a longevity supplement based on the following table. The longevity pay system is approved annually by the Board as a part of the budget process. Longevity increases shall be based upon a percentage of annual wages or salary depending upon the number of consecutive years of employment with the Town, and are granted as part of the last payroll in November.

<u>Years of Service</u>	<u>Longevity Pay</u>
1-5	\$200
6-10	\$400
11-15	\$600
16-20	\$800
More than 20	\$1,000

Longevity pay is based on continuous years of service to the Town. Department Heads is based on years of service in the NC Retirement System. Normal payroll deductions will be made from longevity pay in accordance with federal and State regulations on compensation. An employee must have worked a full year to be eligible to receive longevity pay. Years of service are calculated on a calendar year basis as of November 30 of each year.

**Section 19. Travel and Subsistence Reimbursements**

When it is necessary or desirable for a Town employee to travel to participate in a meeting, conference, workshop, seminar, or to otherwise conduct the Town's business, the Town will bear necessary and reasonable expenses relating to these activities.

The Town will pay all registration costs, including charges for any meals that are included as part of a registration fee for a meeting, conference, workshop or seminar. The Town will pay round trip tourist air fare to destination and cab fare between airports, hotels, and activity sites. The use of economically priced rental cars may be considered. The Town will pay employees on the basis of mileage for the use of their private automobile on Town business. When traveling mileage for one's personal car will be paid

when this cost does not exceed the cost of air travel. The Town will determine the mileage reimbursement based on the most recent rate set by the IRS. Travel by Town vehicles is required whenever available. Parking fees will be reimbursed.

The Town will pay the actual cost of moderately priced out of town lodging, including local taxes and fee charges, for the employee only. If a meeting, conference, etc. is being held at a hotel, the employee may select that hotel for lodging. The Town will pay expenses for extended overnight stay when significant savings may be realized. Such extended stay must be specifically approved by the Town Manager.

The Town will pay for actual cost of meals and gratuities which are deemed reasonable by the Town Manager. Meals or banquets that are included in a meeting, conference, etc. activity or meals where the employee has no practical control over the site or food selection that exceeds these amounts are exempt. The Town will pay reasonable extra costs for these meals and gratuities only when a receipt is furnished and the expense justified. For day activities, the Town will pay for lunch only. Breakfast and dinner costs are not allowable expenses if the activity does not extend overnight. An exception to this rule may be allowed by the Town Manager when an exceptionally early departure or late return is an alternative to an overnight stay.

All tickets and receipts for meals, lodging and other approved expenses shall to be turned in the Finance Officer upon return from travel. The Town Manager shall review and approved travel expenses before payment can be dispensed. There shall be no maximum set for the cost of meals and lodging. However, an employee traveling at Town expense shall use the most economical motel available while traveling.

When submitting mileage for payment the employee shall fill out a Request Mileage Payment form. This form shall include an accurate recording of mileage traveled, purpose of the travel and travel destination, etc. This form shall be given to the Finance Officer for payment.

The Town will not pay for personal expenses that are unrelated to the purpose of the travel activity. Expenses such as, but not limited to, alcoholic beverages, personal telephone calls, newspapers, magazines, room service, movies, premium TV channels and other entertainment will not be reimbursed.

The Department Head or Town Manager shall approve, in advance, all requests to travel on Town business made by those in his or her department and all expenses to be incurred and/or relative to this travel. Because of his/her familiarity with the purpose of the travel and the personnel involved, the Department Head shall closely monitor expenses and question any unreasonable charges incurred and make recommendations to the Town Manager.

The Finance Officer shall also review all travel related transactions and advise the Department Head and Town Manager of any apparent deviations from this policy.

## **ARTICLE IV. RECRUITMENT AND EMPLOYMENT**

### **Section 1. Equal Employment Opportunity Policy**

It is the policy of the Town to foster, maintain and promote equal employment opportunity. The Town shall select employees on the basis of the applicant's qualifications for the job and award them, with respect to compensation and opportunity for training and advancement, including upgrading and promotion, without regard to age, sex, race, color, religion, national origin, non-job related handicap, political affiliation, or marital status. Applicants with physical handicaps shall be given equal consideration with other applicants for positions in which their physical handicaps do not represent an unreasonable barrier to satisfactory performance of duties with or without reasonable accommodation.

### **Section 2. Implementation of Equal Employment Opportunity Policy**

All personnel responsible for recruitment and employment will continue to review regularly the implementation of this personnel policy and relevant practices to assure that equal employment opportunity based on reasonable, job-related job requirements is being actively observed to the end that no employee or applicant for employment shall suffer discrimination because of age, sex, race, color, religion, non-job related handicap, national origin, political affiliation, or marital status. Notices with regard to equal employment matters shall be posted in conspicuous places on Town premises in places where notices are customarily posted.

### **Section 3. Recruitment, Selection and Appointment**

**Recruitment Sources.** When position vacancies occur, supervisors shall notify the Town Manager concerning the number and classification of positions which are to be filled. The Town Manager shall publicize these opportunities for employment, including applicable salary information and employment qualifications. Information on job openings and hiring practices shall be provided to recruitment sources, including organizations and news media available to minority applicants. In addition, notice of vacancies shall be posted at designated conspicuous sites within departments. Individuals shall be recruited from a geographic area as wide as necessary to ensure that well-qualified applicants are obtained for Town service.

**Job Advertisements.** Employment advertisements shall contain assurances of equal employment opportunity and shall comply with Federal and State statutes.

**Application for Employment.** All persons expressing interest in employment with the Town shall be given the opportunity to file an application for employment for positions which are vacant.

Application Reserve File. Applications shall be kept in an inactive reserve file for a period of two years, in accordance with Equal Employment Opportunity Commission guidelines.

Selection. Department Heads shall make such investigations and conduct such examinations as necessary to assess accurately the knowledge, skills, and experience qualifications required for the position and approved in the Position Classification Plan.

Appointment. Before any commitment is made to an applicant either internal or external, the Department Head shall make recommendations to the Town Manager who shall review and approve the position to be filled, the salary to be paid, and the reasons for selecting the candidate over other candidates. The Town Manager shall approve appointments and the starting salary for all applicants.

#### **Section 4. Probationary Period**

An employee appointed or promoted to a permanent position shall serve a probationary period. Employees shall serve a six-month probationary period, except that sworn law enforcement personnel shall serve a probationary period defined by Departmental Policy not to exceed twelve months. Employees hired as "trainees" shall remain on probation until the provisions of their traineeship are satisfied.

During the probationary period, supervisors shall monitor an employee's performance and communicate with the employee concerning performance progress. Before the end of the probationary period, the supervisor shall determine whether the employee is performing satisfactory work and meeting job expectations. The employee's progress (accomplishments, strengths, and weaknesses) will be discussed with the employee and a summary of this discussion should be documented in the employee's personnel file. The supervisor shall recommend in writing whether the probationary period should be completed, extended, or the employee transferred, demoted, or dismissed. Probationary periods may be extended for a maximum of six additional months. Except that the probationary period for sworn police personnel shall not exceed twelve months.

Disciplinary action, including demotion and dismissal, may be taken at any time during the probationary period of a new hire without following the steps outlined in this Policy for disciplinary action. A promoted employee who does not successfully complete the probationary period may be transferred or demoted to a position in which the employee shows promise of success. If no such position is available, the employee shall be dismissed. Promoted employees retain all other rights and benefits such as the right to use the grievance procedures.

Probationary employees are eligible for but not entitled to benefits cited in this policy; however, annual leave may not be taken within this period unless approved by the Department Head.

#### **Section 5. Promotion**

Promotion is the movement of an employee from one position to another vacant position in a class assigned to a higher salary range. It is the Town's policy to create career opportunities for its employees whenever possible. Therefore, when a current employee applying for a vacant position is best suited of all applicants, that applicant shall be promoted to that position. The Town will balance three goals in the employment process:

- 1) the benefits to employees and the organization of promotion from within;
- 2) providing equal employment opportunity and a diversified workforce to the community; and

- 3) obtaining the best possible employee who will provide the most productivity in that position. Candidates for promotion shall be chosen on the basis of their qualifications and their work records. Candidates shall apply for promotions using the same application process as external candidates.

#### **Section 6. Demotion**

Demotion is the movement of an employee from one position to a position in a class assigned to a lower salary range. An employee whose work or conduct in the current position is unsatisfactory may be demoted provided that the employee shows promise of becoming a satisfactory employee in the lower position. Such demotion shall follow the disciplinary procedures outlined in this chapter. Demoted employees may appeal this decision based on the Grievance Process outlined in this Personnel Policy.

#### **Section 7. Transfer**

Transfer is the movement of an employee from one position to another position in a class at the same salary range. If a vacancy occurs and an employee in another department is eligible for a transfer, the employee shall apply for the transfer using the usual application process. The Department Head wishing to transfer an employee to a different department or classification shall make a recommendation to the Town Manager. Any employee transferred without requesting the action may appeal the action in accordance with the grievance procedure outlined in this chapter. An employee who has successfully completed a probationary period may be transferred into the same classification without serving another probationary period. It is the policy of the Town to transfer employees temporarily or permanently from one department to another when doing so will serve the Town's best interest, to permit maximum utilization of personnel during unanticipated emergency situation, during peak workloads, and for shifting help to where it is most needed.



## ARTICLE V. CONDITIONS OF EMPLOYMENT

### Section 1. Work Schedule

Department Heads shall establish work schedules, with the approval of the Town Manager, which meet the operational needs of the department in the most cost effective manner possible.

Normally a full-time employee, except in police services, works an eight-hour day for five days per week for a total of forty hours during a work week. Police may work up to 171 hours within a twenty eight day cycle.

### Section 2. Political Activity

Each employee has a civic responsibility to support good government by every available means and in every appropriate manner. Each employee may join or affiliate with civic organizations of a partisan or political nature, may attend political meetings, may advocate and support the principles or policies of civic or political organizations in accordance with the Constitution and laws of the State of North Carolina and in accordance with the Constitution and laws of the United States. However, no employee shall:

- a) Engage in any political or partisan activity while on duty;
- b) Use official authority of influence for the purpose of interfering with or affecting the result of a nomination or an election for office;
- c) Be required as a duty of employment or as condition for employment, promotion or tenure of office to contribute funds for political or partisan purposes;
- d) Coerce or compel contributions from another employee of the Town for  
political  
or partisan purposes;
- e) Use any supplies or equipment of the Town for political or partisan purposes;
- f) Be a candidate for nomination or election to office under the Town Charter.

Any violation of this section shall subject the employee to disciplinary action including dismissal.

### **Section 3. Outside Employment**

The work of the Town shall have precedence over other occupational interests of employees. All outside employment for salaries, wages, or commission and all self-employment must be reported in advance to the employee's Department Head, who in turn will report it to the Town Manager. The Town Manager will review such employment for possible conflict of interest and then approve or disapprove the secondary employment. If subsequent questions or issues arise the employee must provide full disclosure regarding all aspects of secondary employment. Conflicting or unreported outside employment is grounds for disciplinary action up to and including dismissal.

### **Section 4. Employment of Relatives**

The Town prohibits the hiring and employment of immediate family in regular positions within the same work unit. "Immediate Family" is defined in Article VII, Section 12. The Town also prohibits the employment of any person into a regular position who is an immediate family member of individuals holding the following positions: Town Manager or Town Clerk. Otherwise, the Town will consider employing family members or related persons in the service of the Town, provided that such employment does not result in relatives supervising relatives.

### **Section 5. Harassment**

Harassment on the basis of race, color, religion, gender, national origin, age or disability constitutes discrimination. The Town opposes harassment by supervisors and employees of the Town in any form. Harassment is verbal or physical conduct that denigrates or shows hostility or aversion toward an individual because of his or her race, color, religion, gender, national origin, age, or disability, or that of his or her relatives, friends, or associates.

Sexual harassment is defined as unwelcome sexual advances, requests for sexual favors, and other verbal or physical conduct of a sexual nature when 1) submission to such conduct is made either explicitly or implicitly a term or condition of an individual's employment; 2) submission to or rejection of such conduct by an individual is used as the basis for employment decisions affecting such individual; or 3) such conduct has the purpose or effect of unreasonably interfering with an individual's work performance or creating an intimidating, hostile, or offensive working environment.

Any employee who believes that he or she may have a complaint of harassment may file the complaint directly with the Town Manager. If the complaint is against the Town Manager, then the complaint shall be submitted in writing to the Town Clerk for transmission to the Town Board. The Town Manager or Town Board will conduct an investigation into any allegation of sexual harassment and advise the employee and appropriate management officials of the outcome of the investigation. Employees witnessing harassment shall also report such conduct to an appropriate Town official.

### **Section 6. Acceptance of Gifts and Favors**

All employees will comply with any state law relating to the acceptance of gifts and favors. No official or employee of the Town shall accept any gift, favor, or thing of value that may tend to influence such employee in the discharge of the employee's duties, or grant in the discharge of duty an improper favor, service, or thing of value. The prohibition of unsolicited gifts is limited to circumstances of improper influence. In de minimus situations, such as meal checks or promotional key chains and the like, some modest maximum dollar value should be determined by the Town. This Section is not intended to isolate employees from normal social practices where gifts among friends, associates, and relatives are appropriate.

### **Section 7. Performance Evaluation**

Department Heads shall conduct performance evaluation conferences with each employee at least once a year. These performance evaluations shall be documented in writing and placed in the employee's personnel file. Procedures for the performance evaluation program shall be determined by the Town Manager.

### **Section 8. Safety**

Safety is the responsibility of both the Town and employees. It is the policy of the Town to establish a safe work environment for employees. The Town shall establish a safety program including policies and procedures regarding safety practices and precautions and training in safety methods in compliance with the provisions of the Occupational Safety and Health Act. Department Heads and supervisors are responsible for insuring the safe work procedures of all employees and providing necessary safety training programs. Employees shall follow the safety policies and procedures and attend safety training programs. Employees who violate such policies and procedures shall be subject to disciplinary action up to and including dismissal. As a part of its safety program, the Town Board will approve a detailed drug and alcohol abuse policy with accompanying processes and procedures.

### **Section 9. Reporting Personal Injuries**

Any employee who is injured in the course of employment (on the job) with the Town or sustains any injury that may affect their ability to perform their job shall report all injuries to their Department Head within 24 hours of injury. All pertinent information shall be reported to the Town Manager so that appropriate action may be taken.

### **Section 10. Reporting Accidents Involving Town Property/Equipment**

All accidents involving Town property and equipment shall be reported immediately to a Department Head. Department Heads will report this information to the Town Manager. All accidents involving Town property and equipment will be subject to investigation by the Town Manager. In consultation with the Town Manager, Department Heads shall take appropriate action in regard to insurance claims as soon as possible following the reported accident.

### **Section 11. Immigration Law Requirements**

All employees are required to furnish proof of citizenship or other required documents indicating a legal right to work in the United States. Copies of the completed I-9 form shall be a permanent part of their personnel file. The Town must comply with all Federal and State laws relating to the verification of citizenship.

### **Section 12. Use of Town Owned Vehicles**

All Town employees, who are assigned or authorized to use Town vehicles, are required to use these vehicles only in the course of driving these vehicles to and from work, only in the course of the employee's assigned duties and responsibilities as an employee of the Town, and only relating to the specific position for which that employee is employed. Employees who operate Town vehicles must report to their Department Head if they are charged with any moving violation while at work or otherwise. An employee who violates these requirements and privileges will be subject to disciplinary action, loss of vehicle use privileges, and possible termination of employment. "Take home" vehicles must be approved by the Town Manager. Employees are not allowed to alter Town owned vehicles without prior approval.

### **Section 13. Post-Accident Testing**

All employees will be required to undergo urine and breath testing if they are involved in an accident while on official Town business that results in a fatality. In addition, a post- accident test will be conducted if an accident results in injuries requiring immediate transportation to a medical treatment facility; or one or more vehicles incurs disabling damage; unless the Town employee can be completely discounted as a contributing factor to the accident. Following an accident, the employee will be tested as soon as possible, but not to exceed eight hours for alcohol testing and 32 hours for drug testing. An employee involved in an accident must refrain from alcohol use for eight hours following the accident or until he/she undergoes a post-accident test. Any employee who leaves the scene of the accident without justifiable explanation prior to submission to drug and alcohol testing will be considered to have refused the test and their employment will be terminated.

Employees tested under this provision will include any employee whose performance could have contributed to the accident. Department Head or supervisor will accompany employee to be tested to the appointment for drug/alcohol testing.

### **Section 14. Uniforms**

The Town may require certain employees to wear uniforms or dress in a manner that conveys an appropriate public image while in the service of the Town. Employees are not allowed to alter uniforms.

## **ARTICLE VI. EMPLOYEE BENEFITS**

### **Section 1. Eligibility**

All full-time employees of the Town are eligible for employee benefits as provided for in this Article which are subject to change at the Town's discretion. Part-time and temporary employees are eligible only for Workers' Compensation.

### **Section 2. Group Health, Hospitalization, Vision and Dental Insurance**

The Town provides group health and hospitalization insurance programs for full-time employees after thirty days of employment. Employees may elect to include coverage for qualified dependents. This coverage is paid for by the employee.

Information concerning cost and benefits shall be available to all employees through the Town Finance Office.

### **Section 3. Life and Disability Insurance**

The Town may elect to provide life insurance for each employee subject to the stipulations of the insurance contract. Life insurance will be provided by the Town in the amount specified in the Town's Life Insurance Policy, subject to appropriation.

### **Section 4. Other Optional Group Insurance Plans**

The Town may make other group insurance plans available to employees upon funding by the Town Board and approval of the Town Manager.

### **Section 5. Retirement**

Each employee who is expected to work for the Town more than 1,000 hours annually shall join the North Carolina Local Governmental Employees' Retirement System when eligible under Section 1 of this Article. New employees will be enrolled in the System after six (6) months of employment. This waiting period may be waived upon written justification and approval by the Town Manager.

## **Section 6. Supplemental Retirement Benefits (401-K)**

The Town provides contributions of .75% of salary to a 401(K) plan for employees when eligible under Section 1 of this Article. New employees will be enrolled in the System after six (6) months of employment. This waiting period may be waived upon written justification and approval by the Town Manager.

Employees may also make additional contributions under the guidelines set down by the 401(K) plan. A monthly separation allowance is paid to retired law enforcement officers as required by the General Statutes.

## **Section 7. Social Security**

The Town, to the extent of its lawful authority and power, has extended Social Security benefits for its eligible employees and eligible groups and classes of such employees.

Social Security is Federal Government insurance to provide an employee with income in his senior years. Disability and death benefits are also provided by social security.

The cost for Social Security is paid through an automatic payroll tax. The Town matches the money that is deducted from the employee's payroll check for payment into the Social Security Trust Fund.

## **Section 8. Workers' Compensation**

All employees of the (full-time, part-time, and temporary) are covered by the North Carolina Workers' Compensation Act and are required to report all injuries arising out of and in the course of employment to their immediate supervisors at the time of the injury in order that appropriate action may be taken at once.

Responsibility for claiming compensation under the Workers' Compensation Act is on the injured employee and the supervisor and such claims must be filed by the employee with the North Carolina Industrial Commission within two years from date of injury. The Town Manager or designee will assist the employee in filing the claim. An employee having an adverse reaction to a smallpox vaccination received as an employee of the Town will be covered under the Town's Workers' Compensation policy.

## **Section 9. Unemployment Compensation**

In accordance with Public Law 94-566 and subsequent amendments, local governments are covered by unemployment insurance. Town employees who are terminated due to a reduction in force or released from Town service may apply for benefits through the local Employment Security Commission office, where a determination of eligibility will be made.

## **Section 10. Education Assistance Program**

All employees who wish to further their education are encouraged to do so by the Town. Courses taken which are required or determined to be necessary to meet the qualifications of the position held, will be paid for by the Town. Courses which may not be required, but felt to be beneficial to the Town and its employees, may or may not be approved, but will be reviewed on an individual basis by the Town Manager. The Town Manager will also review each situation to determine if such courses will be paid for by the Town, by the employee, or shared by both. The Town Manager will make a determination as to whether absence for work as a result of these courses can be justified at the particular time. The Town will support training courses, seminars and conferences to maintain current job knowledge to the extent funds are available.

Conditions and Agreement. Because the Town expends resources in helping employees with tuition costs, employees should use their newly acquired training in service to the Town. Thus, an employee must agree to remain employed by the Town for two years following the date of reimbursement or repay the Town on a pro-rated schedule for the amount of the reimbursement. Employees reduced in force are exempt from this repayment. The amount owed will be deducted from the employee's last pay check, including cost of tuition, books and fees.

#### **Section 11. Flexible Benefits Plan (125 Plan)**

The Town may upon authorization by the Town Board provide for the availability of a flexible benefits plan under IRS Code Section 125 which would allow pre tax deductions from payroll checks for certain eligible benefit programs as specified by Section 125.

### **ARTICLE VII. HOLIDAYS AND LEAVES OF ABSENCE**

#### **Section 1. Policy**

The policy of the Town is to provide annual leave, sick leave, and holiday leave to all full- time employees, and to provide proportionately equivalent amounts to employees having average work weeks of different lengths.

#### **Section 2. Leave Pro-rated**

Holiday, annual, and sick leave earned by full-time employees with fewer or more hours than the basic work week shall be determined by the following formula:

- 1) The number of hours worked by such employees shall be divided by the number of hours in the basic work week (usually 40 hours).
- 2) The proportion obtained in step 1 shall be multiplied by the number of hours of leave earned annually by employees working the basic work week.
- 3) The number of hours in step 2 divided by 12 shall be the number of hours of leave earned monthly by the employees concerned.

#### **Section 3. Holidays**

The policy of the Town is to follow the holiday schedule listed below: Each holiday is an eight-hour period.

New Year's Day

Martin L. King, Jr. Day

Good Friday

Memorial Day

Independence Day

Labor Day

Columbus Day

Veteran's Day

Thanksgiving Day, Day after Thanksgiving Christmas – three (3) Work Days

When a holiday other than Christmas Day falls on a Saturday or Sunday, The Town Manager shall determine that Monday or Friday shall be observed as a holiday. Any conflict in the date of the holiday shall be decided by the Town Manager or designee. The Town Manager shall designate the Christmas

Holidays each year, depending on which day Christmas actually falls. If Christmas falls on a Wednesday or Thursday, the town may observe a 3 day holiday with approval of the Town Board. In order to be eligible for holiday pay, an employee must have worked the day before and the day after the holiday(s), or have been granted approved leave.

**Section 4. Holidays: Effect on Other Types of Leave**

Regular holidays which occur during an annual, sick or other leave period of any employee shall not be considered as annual, sick, or other leave.

**Section 5. Holidays: Compensation for Shift Personnel**

Employees required to perform work on regularly scheduled holidays may be granted compensatory time off or paid at their hourly rate for proportional hours based on the pro-rated hours outlined in Section 2 above in addition to any holiday pay to which they are entitled. Compensatory time shall be granted whenever feasible and taken within 30 days from the time it is earned.

If a holiday falls on a regularly scheduled off-duty day for shift personnel, the employee shall receive the hours for paid holiday leave at another time. Department Heads are to ensure that this compensatory time is granted within 30 days, and if this is not feasible the Department Head shall discuss the situation with the Town Manager. Normally the employee shall be paid for the holiday compensatory time after 120 days, if time off is not taken. During annual budget preparation, the Town Board may appropriate funds to compensate shift employees with 8 hours of pay for each holiday, such appropriation being dependent on the availability of funds.

Law Enforcement Holiday Compensation will refer to the Police Department’s current Policy.

**Section 6. Annual Leave**

Annual leave shall be used for rest and relaxation, and may be used for medical appointments or sickness when sick leave is exhausted. Any compensatory time earned by the employee must be used prior to using annual leave.

**Section 7. Annual Leave: Use by Probationary Employees**

Employees serving a probationary period following initial employment may accumulate annual leave but shall not be permitted to take annual leave during the probationary period without special approval by the Town Manager. Employees shall be allowed to take accumulated annual leave after six months of service.

**Section 8. Annual Leave: Accrual Rate**

Each full-time employee of the Town shall accrue annual leave on the following schedule for each completed month (calendar month) of service, pro-rated by the number of hours in the work week:

<b>Years of Service</b>	<b>Hours Earned Monthly</b>	<b>Hours Earned Annually</b>
<b>Less than 6</b>	<b>6.66</b>	<b>79.92</b>
<b>6</b>	<b>7.33</b>	<b>87.96</b>
<b>7</b>	<b>8.00</b>	<b>96.00</b>
<b>8</b>	<b>8.66</b>	<b>103.92</b>
<b>9</b>	<b>9.33</b>	<b>111.96</b>

<b>10-15</b>	<b>10.00</b>	<b>120.00</b>
<b>16</b>	<b>10.66</b>	<b>127.92</b>
<b>17</b>	<b>11.33</b>	<b>135.96</b>
<b>18</b>	<b>12.00</b>	<b>144.00</b>
<b>19</b>	<b>12.66</b>	<b>151.92</b>
<b>More than 19</b>	<b>13.33</b>	<b>159.96</b>

**Section 9. Annual Leave: Maximum Accumulation**

Annual leave may accumulate during the year up to 240 hours. Any employee with more than 240 hours of accumulated leave during the year shall have the excess accumulation converted to the employee's sick leave. Employees are not eligible to receive pay for annual leave time not taken.

**Section 10. Annual Leave: Manner of Taking**

Annual leave may be taken as earned by the employee with the exception of provisions applying to probationary employees. Annual leave is subject to the approval of the supervisor and the Town Manager.

**Section 11. Annual Leave: Payment upon Separation**

An employee who has successfully completed six months of the probationary period will normally be paid for accumulated annual leave upon separation not to exceed 240 hours, provided notice is given to the supervisor at least two weeks in advance of the effective date of resignation. Any employee failing to give the notice required by this section shall forfeit payment for accumulated leave. The notice requirement may be waived by the Town Manager when deemed to be in the best interest of the Town. Employees who are involuntarily separated may receive payment for accumulated annual leave subject to the 240 hour limit and based on the individual circumstances as determined and approved by the Town Manager. At the time of separation, any annual leave owed the Town shall be deducted from the employee's final compensation.

**Section 12. Annual Leave: Payment Upon Death**

The estate of an employee who dies while employed by the Town shall be entitled to payment of all the accumulated annual leave credited to the employee's account not to exceed the maximums established in Section 8 of this Article.

**Section 13. Sick Leave**

Sick leave with pay is not a right which an employee may demand, but a privilege granted for the benefit of an employee when sick. Sick leave may be granted to an employee absent from work for any of the following reasons: sickness, bodily injury, required physical or dental examinations or treatment, or exposure to a contagious disease, when continuing work might jeopardize the health of others. Sick leave may also be used by either parent for the birth of a child during the mother's period of disability, and for adoption not to exceed a period of six weeks.

Sick leave may be used when an employee must care for a member of his or her immediate family who is ill. Sick leave may also be used for funeral attendance.



Sick leave may also be used to supplement Workers' Compensation Disability Leave both during the waiting period before Workers' Compensation benefits begin, and afterward to supplement the remaining salary, except that employees may not exceed their regular salary amount using this provision.

"Immediate family" shall be defined as spouse, parent, guardian, children, sister, brother, grandparents, grandchildren plus the various combinations of half, step, in-law, and adopted relationships that can be derived from those named.

Notification of the desire to take sick leave should be submitted to the employee's supervisor prior to the leave. Failure to do so appropriately may result in disciplinary action.

#### **Section 14. Sick Leave: Accrual Rate and Accumulation**

Sick leave shall accrue at the rate of 8 hours per month for each completed month (calendar month) of service: An employee must work at least 15 days of a month to gain credit for the month.

Sick leave will be cumulative for an indefinite period of time and may be converted upon retirement for service credit consistent with the provisions of the North Carolina Local Government Employees' Retirement System.

Any compensatory time earned by an employee shall be taken first prior to using the sick leave account. Sick leave shall be taken in hour units.

All sick leave accumulated by an employee shall end and terminate without compensation when the employee resigns or is separated from the Town, except as stated for employees retiring or terminated due to reduction in force.

#### **Section 15. Sick Leave: Medical Certification**

The Department Head or the Town Manager may require a physician's certificate stating the nature of the employee or immediate family member's illness and the employee's capacity to resume duties, for each occasion on which an employee uses sick leave or whenever the supervisor observes a "pattern of absenteeism." The employee may be required to submit to such medical examination or inquiry as the Department Head deems desirable. The Department Head shall be responsible for the application of this provision to the end that:

- 1) Employees shall not be on duty when they might endanger their health or the health of other employees; and
- 2) There will be no abuse of leave privileges.

Claiming sick leave under false pretense to obtain a day off with pay shall subject the employee to disciplinary action.

#### **Section 16. Leave Without Pay**

A full or part-time employee may be granted a leave of absence without pay for a period of up to six months by the Town Manager. The leave shall be used for reasons of personal disability after both sick leave and desired amount of annual leave have been exhausted, sickness or disability of immediate family members, continuation of education, special work that will permit the Town to benefit by the experience gained or the work performed, or for other reasons deemed justified by the Town Manager. The employee must pay the full cost of insurance during this period to continue insurance benefits.

The employee shall apply in writing to the supervisor for leave. The employee is obligated to return to duty within or at the end of the time determined appropriate by the Town Manager. Upon returning to duty after being on leave without pay, the employee shall be entitled to return to the same position held at the time leave was granted or to one of like classification, seniority, and pay. If the employee decides not to return to work, the supervisor shall be notified immediately. Failure to report at the expiration of a leave of absence, unless an extension has been requested, shall be considered a resignation.

#### **Section 17. Leave Sharing**

Employees may share accumulated annual leave with other Town employees in cases of extended medical illness or accident which requires continued absence from work. An employee may make application for him/herself or for another employee to be considered for the shared leave program. Approval of the Town Manager is required. An employee may share an unlimited number of annual hours, but must maintain a balance of at least

40 hours. Procedures will be established by the Town Manager for application and approval process. Medical certification may be required according to the medical certification policy. If an employee does not have to use all the hours that are donated, the remaining balance will be credited back, on a pro-rated basis, to those employees who donated leave.

If two employees of the Town qualify under the "immediate family" definition, consideration may be granted for sharing sick leave.

#### **Section 18. Workers' Compensation Leave**

An employee absent from duty because of sickness or disability covered by the North Carolina Workers' Compensation Act may elect to use accrued sick leave or annual during the first waiting period. The employee may also elect to supplement workers' compensation payments after they begin provided that the combination of leave supplement and workers' compensation payments does not exceed normal compensation. An employee on workers' compensation leave will be permitted to continue to be eligible for benefits under the Town's group insurance plans.

#### **Section 19. Military Leave**

Regular employees who are members of an Armed Forces Reserve organization or National Guard shall be granted ten workdays per year for military leave with pay. On rare occasions due to annual training being scheduled on a federal fiscal year basis, an employee may be required to attend two periods of training in one calendar year. For this purpose only, an employee shall be granted an additional ten days of military leave during the same calendar year. Any salary payments which the employee receives from the military shall be deducted from the sum paid by the Town. The effect will be to maintain the employee's salary at the normal level during this period. If such duty is required beyond this ten workdays, the employee shall be eligible to take accumulated annual leave or be placed in a leave without pay status, and the provisions of that leave shall apply. While taking military leave without pay or with partial pay, the employee's leave credits and other benefits shall continue to accrue as if the employee physically remained with the Town during this period. Employees who are eligible for military leave have all job rights specified by the Vietnam Veterans Readjustment Act, including members of the National Guard or a reserve unit.

**Section 20. Reinstatement Following Military Service.**

An employee called to extended active duty with the United States military forces, who does not volunteer for service beyond the period for which called, shall be reinstated with full benefits provided the employee:

- 1) Applies for reinstatement within ninety days after the release from military service; and
- 2) Is able to perform the duties of the former position or similar position; or
- 3) Is unable to perform the duties of the former position or a similar position due to disability sustained as a result of military service, but is able to perform the duties of another position in the service of the Town. In this case the employee shall be employed in such other position as will provide the nearest approximation of the seniority, status, and pay which the employee otherwise would have been provided, if available.

**Section 21. Civil Leave**

A Town employee called for jury duty or as a court witness for the federal or state governments, or a subdivision thereof, shall receive leave with pay for such duty during the required absence without charge to accumulated leave. The employee may keep fees and travel allowances received for jury or witness duty in addition to regular compensation; except, that employees must turn over to the Town any witness fees or travel allowance awarded by that court for court appearances in connection with official duties. While on civil leave, benefits and leave shall accrue as though on regular duty.

**Section 22. Hazardous Weather Conditions**

If an employee cannot make it to work due to hazardous conditions caused by the weather, the employee must notify their supervisor no later than one hour after the current workday has begun. If an employee fails to notify their supervisor he/she will be charged leave without pay. It shall be the Town Manager's responsibility to decide whether or not weather conditions are severe enough to cancel work for the day.

**Section 23. Funeral Leave**

A maximum of five days paid funeral leave may be allowed should there be a death in the employees' immediate family. Immediate family shall be defined as spouse, children, mother, father, brother, sister, mother-in-law, father-in-law, grandparents and grandchildren. All funeral leave must be approved by the Town Manager in advance.

**Section 24. Petty Leave/Community Service Leave**

An employee of the Town will be allowed 16 hours per year of petty/community service leave with pay over and above all leaves. This leave may be used for appointments other than medical, emergencies, ... The Town Manager shall approve all leaves taken in this manner. An employee may take no more than two (4) hours of petty leave at one time. Any time taken over two (4) hours at a time must be charged to another type of leave.

*Community Service Leave Defined:*

- (1) Leave for Child Involvement and School Volunteerism: Employees may use all or part of their annual allotment of Community Service Leave to volunteer time in support of programs and services in public and private elementary, middle and high schools, and licensed public and private child care and pre-school settings. A parent may use this leave to meet with a teacher or

administrator concerning the parent's child or may attend any educational function sponsored by the school in which the child is participating.

- (2) Leave for Non-Profit Organization Volunteerism: Employees may use all or part of their annual 10-hour allotment of Community Service Leave to volunteer in non-profit, non-partisan community organizations which are designated as 501(c)(3) agencies under the Internal Revenue Code, or human services organizations licensed or accredited to serve citizens with special needs including children, youth and the elderly.

### **Section 25. Family and Medical Leave**

The Town will grant up to 12 weeks of family and medical leave per twelve months to eligible employees in accordance with the Family and Medical Leave Act of 1993 (FMLA) or subsequent amendments. The leave may be paid (coordinated with the Town's Vacation and Sick Leave policies), unpaid, or a combination of paid and unpaid. Earned Compensatory time may also be used during FMLA leave. Unpaid leave will be granted only when the employee has exhausted all appropriate types of paid leave. Additional time away from the job beyond the 12-week period may be approved in accordance with the Town's Leave with Pay policy.

To qualify for FMLA coverage, the employee must have worked for the employer 12 months or 52 weeks; these do not have to be consecutive. However, the employee must have worked 1,250 hours during the twelve-month period immediately before the date when the FMLA time begins.

Family and medical leave can be used for the following reasons:

- 1) The birth of a child and in order to care for that child;
- 2) The placement of a child for adoption or foster care;
- 3) To care for a spouse, child, or parent with a serious health condition;
- 4) The serious health condition of the employee; or
- 5) Military exigency.

An employee who takes leave under this policy will return to the same job or a job with equivalent status, pay, benefits, and other employment terms. The position will be the same or one which entails substantially equivalent skills, effort, responsibility, authority.

A serious health condition is defined as a condition which requires inpatient care at a hospital, hospice, or residential medical care facility, or a condition which requires continuing care by a licensed health care provider. This policy covers illness of a serious and long-term nature resulting in recurring or lengthy absences. Generally, a chronic or long term health condition which results in a period of incapacity of more than three days would be considered a serious health condition.

If a husband and wife both work for the Town and each wishes to take leave for a birth of a child, adoption or placement of a child in foster care, or to care for a parent (not parent in-law) with a serious health condition, the husband and wife together may only take a total of 12 weeks leave under FMLA.

An employee taking leave for the birth of a child may use paid sick leave for the period of actual disability, based on medical certification. The employee shall then use all paid vacation and accrued compensatory time for the remainder of the 12-week period.

The request for the use of leave must be made in writing by the employee and approved by the Town Manager.

An employee who takes leave under this policy will return to the same job or a job with equivalent status, pay, benefits, and other employment terms. The position will be the same or one which entails substantially equivalent skill, effort, responsibility, and authority.

“Military Exigency” is a qualifying exigency arising out of the fact that the employee’s spouse, son, daughter, or parent is a military service member (reserve or National Guard) under a call or order to federal active duty in support of a contingency operation. Qualifying events are:

- 1) Deployment of service member with seven or fewer days’ notice;
- 2) Military ceremonies and events such as family-assistance or informational programs related to the family member’s active duty or call to active duty;
- 3) Urgent, immediate childcare or arranging for alternative childcare for the children of service members;
- 4) Attending school or daycare meetings relating to the child of service member;
- 5) Making financial or legal arrangements related to a family member’s active duty status or call to active duty; or
- 6) Post-deployment activities for a period of ninety days after the termination of the service member’s active duty status.

Military Caregiver Leave: An employee whose spouse, son, daughter, parent or next of kin is a current service member who is undergoing treatment, therapy, recuperation or outpatient treatment or has temporary disability retirement for injury or illness sustained in the line of duty, is eligible for 26 weeks of leave in a single 12 month period. During a single 12 month period, the employee is eligible for a total of 26 weeks of all types of FMLA leave.

### **Section 26. Medical & Family Leave – Certification**

In order to qualify for leave under this law, the Town requires medical certification. This statement from the employee’s or the family member’s physician should include the date when the condition began, its expected duration, diagnosis, and brief statement of treatment. For the employee’s own health condition, it should state that the employee is unable to perform the essential functions of his/her position. For a seriously ill family member, the certification must include a statement that the patient requires assistance and the employee’s presence would be beneficial or desirable.

This certification should be furnished at least 30 days prior to the needed leave unless the employee’s or family member’s condition is a sudden one. The certification should be furnished as soon as possible (no longer than 15 days from the date of the employee’s request). The certification and request must be made to the Town Manager.

The employee is expected to return to work at the end of the time frame stated in the medical certification, unless he/she has requested additional time in writing under the Town’s Leave Without Pay policy.

### **Section 27. FMLA & Leave Without Pay: Retention & Benefit Continuation**

When an employee is on leave under the FMLA (maximum of 12 weeks in a year), the Town will continue the employee's health benefits during the leave period at the same level and under the same conditions as if the employee had continued to work. If an employee chooses not to return to work for reasons other than a continued serious health condition, the Town will require the reimbursement of the amount paid for the employee's health insurance premium during the FMLA leave period.

Other insurance and payroll deductions are the responsibility of the employee and the employee must make those payments for continued coverage of that benefit.

An employee shall retain all unused vacation and sick leave while on Leave Without Pay. An employee ceases to earn leave credits on the date leave without pay begins. The employee may continue to be eligible for benefits under the Town's group insurance plans at his or her own expense, subject to any regulation adopted by the Board of Commissioners and the regulations of the insurance carrier.

### **Section 28. Bereavement Leave**

It is The Town's policy to provide eligible employees with paid bereavement leave following the death of an immediate family member. An employee is allowed five working days per occurrence (for employees working a flexible work schedule, part time, or compressed schedule, the allotment is prorated based on their regular weekly schedule).

- Immediate family members include:
- Parents Siblings Spouse Children
- Domestic partner\* Mother/father-in-law Sister/brother-in-law Daughter/son-in-law Grandparent Grandchild
- Domestic partner's mother, father, sister, brother, son or daughter Spouse's or domestic partner's grandparent or grandchild
- An adult who stood "in loco parentis" during an employees childhood Step-children
- Step-parents
- \*Domestic partner means an adult of the same or opposite sex engaged in a spouse-like relationship characterized by mutual caring and dependency.

Generally, bereavement leave is taken immediately following the death. However, there may be circumstances when a manager will recognize the need for flexibility, for example, if a memorial service is scheduled at a time in the future.

An employee should notify his or her supervisor of the need to take bereavement leave as soon as possible.

Employees with an attendance warning or other attendance issues may be asked to provide documentation regarding their request for bereavement leave.

## **ARTICLE VIII. SEPARATION AND REINSTATEMENT**

### **Section 1. Types of Separations**

All separations of employees from positions in the service of the Town shall be designated as one of the following types and shall be accomplished in the manner indicated: Resignation, reduction in force, disability, voluntary retirement, dismissal, or death. In all cases except for death, the Town requires that Town owned equipment, uniforms etc. Be turned in on or before the Employees last day of service, or within 24 hours of employee's last day of service at the discretion of the Department Head.

### **Section 2. Resignation**

An employee may resign by submitting the reasons for resignation and the effective date in writing to the immediate supervisor as far in advance as possible. In all instances, the minimum notice requirement is two weeks. Failure to provide minimum notice shall result in forfeit of payment for accumulated annual leave unless the notice is waived upon recommendation of the supervisor and approval by the Town Manager.

Three consecutive days of absence without contacting the immediate supervisor or Department Head is considered to be a voluntary resignation.

### **Section 3. Reduction in Force**

In the event that a reduction in force becomes necessary, consideration shall be given to the quality of each employee's performance, organizational needs, and seniority in determining those employees to be retained. Employees who are separated because of a reduction in force shall be given at least two weeks' notice of the anticipated action.

No regular employee shall be separated while there are temporary or probationary employees serving in the same class in the department, unless the regular employee is not willing to transfer to the position held by the temporary or probationary employee.

### **Section 4. Disability**

An employee who cannot perform the required duties because of a physical or mental impairment may be separated for disability. Action may be initiated by the employee or the Town. In all cases, such action must be accompanied by medical evidence acceptable to the Town Manager. The Town may require an examination, at the Town's expense, performed by a physician of the Town's choice.

### **Section 5. Voluntary Retirement**

An employee who meets the conditions set forth under the provision of the North Carolina Local Government Employee's Retirement System may elect to retire and receive all benefits earned under the retirement plan.

### **Section 6. Death**

Separation shall be effective as of the date of death. All compensation due shall be paid to the estate of the employee.

### **Section 7. Dismissal**

An employee may be dismissed in accordance with the provisions and procedures of Article IX.

### **Section 8. Reinstatement**

An employee who is separated because of reduction in force may be reinstated within one year of the date of separation, upon recommendation of the supervisor and approval of the Town Manager. An employee who is reinstated in this manner shall be re-credited with his or her previously accrued sick leave.

### **Section 9. Rehiring**

An employee who resigns while in good standing may be rehired after one year with the approval of the Town Manager, and shall be regarded as a new employee, subject to all of the provisions of rules and regulations of this Chapter. However, the employee shall be credited with his or her previously accrued sick leave if he or she is rehired within five years. An employee in good standing who is separated due to a reduction in force shall be given the first opportunity to be rehired in the same or a similar position.

## **ARTICLE IX. UNSATISFACTORY JOB PERFORMANCE AND DETRIMENTAL PERSONAL CONDUCT**

### **Section 1. Disciplinary Action for Unsatisfactory Job Performance**

A regular employee may be placed on disciplinary suspension, demoted, or dismissed for unsatisfactory job performance, if after following the procedure outlined below, the employee's job performance is still deemed to be unsatisfactory.

### **Section 2. Unsatisfactory Job Performance Defined**

Unsatisfactory job performance includes any aspects of the employee's job which are not performed as required to meet the standards set by the supervisor. Examples of unsatisfactory job performance include, but are not limited to, the following:

- 1) Demonstrated inefficiency, negligence, or incompetence in the performance of duties;
- 2) Careless, negligent or improper use of Town property or equipment;
- 3) Physical or mental incapacity to perform duties;
- 4) Discourteous treatment of the public or other employees;
- 5) Absence without approved leave;
- 6) Repeated improper use of leave privileges;
- 7) Habitual pattern of failure to report for duty at the assigned time and place;
- 8) Insubordination or violation of the organization's hierarchy;
- 9) Failure to complete work within time frames established in work plan or work standards; or
- 10) Failure to meet work standards over a period of time.

### **Section 3. Communication and Warning Procedures**

When an employee's job performance is unsatisfactory, or when incidents or inappropriate actions warrant, the Department Head should meet with the employee as soon as possible in one or more counseling sessions to discuss specific performance problems. A brief summary of these counseling sessions should be noted in the employee's file by the supervisor. An employee whose job performance is unsatisfactory over a period of time should normally receive at least two warnings from the supervisor before disciplinary action resulting in dismissal is taken by the Department Head. This Section will not be interpreted as mandating two warnings prior to dismissal in all instances. In each case, the supervisor should record the dates of discussions with the employee, the performance deficiencies discussed, the corrective actions recommended, and the time limits set. If the employee's performance continues to be unsatisfactory, then the supervisor should use the following disciplinary steps:



- 1) A final written warning from the Department Head serving notice upon the employee that corrected performance must take place immediately in order to avoid suspension, demotion, or dismissal.
- 2) If performance does not improve, the Department Head should initiate a Disciplinary Conference as detailed in Section 6 of this Article.

#### **Section 4. Disciplinary Action for Detrimental Personal Conduct**

With the approval of the Town Manager, an employee may be placed on disciplinary suspension or dismissed without prior warning or counseling for causes relating to personal conduct detrimental to Town service in order to 1) avoid undue disruption of work; 2) to protect the safety of persons or property; or 3) for other serious reasons.

#### **Section 5. Detrimental Personal Conduct Defined**

Detrimental personal conduct includes behavior of such a serious detrimental nature that the functioning of the Town may be or has been impaired; the safety of persons or property may be or have been threatened; or the laws of the government may be or have been violated. Examples of detrimental personal conduct include, but are not limited to, the following:

- 1) Fraud;
- 2) Commission of a felony or the entry of a plea of nolo contendere thereto;
- 3) Falsification of records for personal profit, to grant special privileges, or to obtain employment;
- 4) Willful misuse or gross negligence in the handling of Town funds;
- 5) Willful or wanton damage or destruction to property;
- 6) Willful or wanton acts that endanger the lives and property of others;
- 7) Possession of unauthorized firearms or other lethal weapons on the job;
- 8) Brutality in the performance of duties;
- 9) Reporting to work under the influence of alcohol or drugs or partaking of such while on duty. Prescribed medication may be taken within the limits set by a physician as long as medically necessary;
- 10) Engaging in incompatible employment or servicing a conflicting interest;
- 11) Request or acceptance of gifts in exchange for favors or influence;
- 12) Conduct unbecoming a public officer or employee;
- 13) Engaging in political activity prohibited by this chapter;
- 14) Committing a crime or engaging in financial behavior such as declaring bankruptcy that draws into question the employee ability to be trusted with public funds; or
- 15) Making unsubstantiated allegations against coworkers or the town that have been made maliciously or knowingly falsified.

### **Section 6. Disciplinary Conference**

Before any disciplinary action is taken, whether for failure in personal conduct or failure in performance of duties, in consultation with the Town Manager, the Department Head shall, when feasible, meet with the employee and, provide the employee with a written notice of disciplinary action, which will include the nature of the action, recommended effective date, and the reasons for the action. The Department Head will consider the employee's response, if any, to the disciplinary action, and will, within three working days following the conference, notify the employee in writing of the final decision to take disciplinary action. The notice of the final disciplinary action shall contain a statement of the reasons for the action and the employee's appeal rights.

### **Section 7. Non-Disciplinary Suspension**

During the investigation, hearing, or trial of an employee on any criminal charge, or during an investigation related to alleged detrimental personal conduct, or during the course of any civil action involving an employee, when suspension would, in the opinion of the Department Head, be in the best interest of the Town, the Department Head, with the approval of the Town Manager, may suspend the employee for the duration of the proceedings as a non-disciplinary action. In such cases, the Department Head may:

- 1) Temporarily relieve the employee of all duties and responsibilities and place the employee on paid or unpaid leave for the duration of the suspension, or
- 2) Assign the employee new duties and responsibilities and allow the employee to receive such compensation in keeping with the new duties and responsibilities.

If the employee is reinstated following the suspension such employee shall not lose any benefits to which otherwise the employee would have been entitled had the suspension not occurred. If the employee is terminated following suspension, the employee shall not be eligible for any pay from the date of suspension; provided, however, all other benefits with the exception of accrued annual and sick leave shall be maintained during the period of suspension.

## **ARTICLE X. GRIEVANCE & WHISTLE BLOWING PROCEDURE**

### **Section 1. Policy**

It is the policy of the Town to provide a just and prompt procedure for the presentation, consideration, and disposition of employee grievances and for employees to report suspected abuse or wrongdoing "whistle-blowing." The purpose of this Article is to outline the procedure and to assure all employees that a response to their complaints and grievances will be prompt and fair.

### **Section 2. Grievance Defined**

A grievance is a claim or complaint by an employee based upon an event or condition, which affects the circumstances under which an employee works, allegedly caused by misinterpretation, unfair application, or lack of established policy pertaining to employment conditions.

Employees utilizing the grievance procedure shall not be subjected to retaliation or any form of harassment from supervisors or employees for exercising their rights under the grievance procedure. Supervisors or other employees who violate this policy shall be subject to disciplinary action up to and including dismissal.

### **Section 3. Purposes of the Grievance Procedure**

The purposes of the grievance procedure include, but are not limited to:

- 1) Providing employees with a procedure by which their complaints can be considered promptly, fairly, and without reprisal;
- 2) Encouraging employees to express themselves about the conditions of work which affect them as employees;
- 3) Promoting better understanding of policies, practices, and procedures which affect employees;
- 4) Increasing employees' confidence that personnel actions taken are in accordance with established, fair, and uniform policies and procedures; and
- 5) Increasing the sense of responsibility exercised by supervisors in dealing with their employees.

#### **Section 4. Procedure**

When an employee or group of employees has a grievance, the following successive steps are to be taken unless otherwise provided. The number of calendar days indicated for each step should be considered the maximum, unless otherwise provided, and every effort should be made to expedite the process. However, the time limits set forth may be extended by mutual consent. The last step initiated by an employee shall be considered to be the step at which the grievance is resolved. A decision to rescind a disciplinary suspension, demotion or dismissal must be approved by the Town Manager and/or the Town Manager before the decision becomes effective.

Informal Resolution. Prior to the submission of a formal grievance, the employee and Department Head should meet to discuss the problem and seek to resolve it informally. This meeting should be requested and held within five working days of the incident or action giving rise to the problem. Ongoing conditions are not subject to this time restriction but a conference should be scheduled and held as quickly as possible.

**Step 1.** If no resolution to the grievance is reached informally, the employee who wishes to pursue a grievance shall present the grievance to the Department Head in writing. The grievance must be presented within five calendar days of the event or within five calendar days of learning of the event or condition. The Department Head shall respond to the grievance within five calendar days after receipt of the grievance. The Department Head should, and is encouraged to, consult with any employee of the Town in order to reach a correct, impartial, fair and equitable determination or decision concerning the grievance. Any employee consulted by the Department Head is required to cooperate to the fullest extent possible.

The response from the Department Head shall be in writing and signed and dated by the Department Head. In addition, the employee shall sign a copy to acknowledge receipt thereof. The responder at each step shall send copies of the grievance and response to the personnel file.

If the employee is directly supervised by the Town Manager the employee will make this first grievance to the Town Manager.

**Step 2.** If the grievance is not resolved to the satisfaction of the employee by the Department Head, the employee may appeal, in writing, to the Town Manager within five calendar days after receipt of the response from Step 1. The Town Manager shall respond to the appeal, may meet with the employee to discuss the grievance fully, and will make a decision within ten calendar days. The Town Manager's decision is final on all grievances, except dismissal.

**Step 3.** If the grievance is not resolved to the satisfaction of the employee for actions involving dismissal by the Town Manager, the employee may appeal in writing to the Board by submitting their written appeal to the Town Clerk within five calendar days after receipt of the response in Step 2. The Town Manager shall provide documentation and justification to the Board. The Board will make a decision within 30 calendar days. The Board's Decision is final.

#### **Section 5. Grievance & Appeal Procedure for Discrimination**

When an employee, former employee, or applicant believes that any employment action discriminates illegally (i.e. is based on age, sex, race, color, national origin, religion, creed, political affiliation, or disability) he/she has the right to appeal such action using the grievance procedure outlined in this policy. While such persons are encouraged to use the grievance procedure, they shall have the right to appeal directly to the Town Board. An employee or applicant should appeal

an alleged act of discrimination within thirty calendar days of the alleged discriminatory action, but may appeal for up to six months following the action.

### **Section 6. Back Pay Awards**

Back pay and benefits may be awarded to reinstated employees in suspension, and discrimination cases.

### **Section 7. Employee Representation**

In consideration of the practice of the Town to provide a just and prompt procedure for the presentation, consideration, and disposition of employee grievances in a non- adversarial atmosphere, no attorneys will be allowed in the grievance process.

### **Section 8. Whistle Blowing Procedure & Protection**

#### Reporting Misconduct

As a furtherance of the Town's informal open door policy, this section outlines the process through which employees can report:

- Grievous violations of town policy and procedures
- Violations of federal or state law Fraud or theft
- Malfeasance or misfeasance of local, state, or federal resources
- Substantial and specific dangers to public health and safety
- Gross mismanagement, waste, or abuse of authority

Employees are encouraged to attempt a resolution internally prior to seeking an external resolution outside of the Town's authority. Suspected violations committed by other employees may be reported in writing directly to the Town Manager or if the allegations are against the Town Manager or Town Board, directly to the Town Attorney. Receipt of the report will be confirmed in writing within 5 business days.

#### No Retaliation

No employee who in good faith reports a violation of policy or alleged dishonest, illegal, or unethical behavior shall suffer harassment, retaliation, or adverse employment consequences. Any employee found to violate this principal shall be subject to disciplinary action including dismissal. Whistleblowers identities will be kept confidential to the greatest extent possible consistent with the need to conduct an adequate investigation. Whistle blowing may be engaged in anonymously; however, this may compromise the good faith nature of the process and the Town's ability effectively substantiate violations.

#### Resolution

All reports will be promptly investigated and resolved through an appropriate combination of improving employee education, policy changes, reporting to appropriate professional development agencies, disciplinary action including dismissal, and criminal investigation.

## ARTICLE XI. PERSONNEL RECORDS AND REPORTS

### Section 1. Public Information

In compliance with GS 160A-168, the following information with respect to each Town employee is a matter of public record: name; age; date of original employment or appointment to the service; current position title; current salary; date and amount of the most recent increase or decrease in salary; date of the most recent promotion, demotion, transfer, suspension, separation, or other change in position classification; and the office to which the employee is currently assigned. Any person may have access to this information for the purpose of inspection, examination, and copying, during regular business hours, subject only to such rules and regulations for the safekeeping of public records as the Town may adopt.

### Section 2. Access to Confidential Records

All information contained in a Town employee's personnel file, other than the information mentioned above is confidential and shall be open to inspection only in the following instances:

- 1) The employee or his/her duly authorized agent may examine all portions of his/her personnel file except letters of reference solicited prior to employment, and information concerning a medical disability, mental or physical, that a prudent physician would not divulge to the patient.
- 2) A licensed physician designated in writing by the employee may examine the employee's medical record.
- 3) A Town employee having supervisory authority over the employee may examine all material in the employee's personnel file.
- 4) By order of a court of competent jurisdiction, any person may examine all material in the employee's personnel file.
- 5) An official of an agency of the State or Federal Government, or any political subdivision of the State, may inspect any portion of a personnel file when such inspection is deemed by the Town Manager to be necessary and essential to the pursuit of a proper function of the inspecting agency, but no information shall be divulged for the purpose of assisting in a criminal prosecution of the employee, or for the purpose of assisting in an investigation of the employee's tax liability. However, the official having custody of the personnel records may release the name, address, and telephone number from a personnel file for the purpose of assisting in a criminal investigation.
- 6) An employee may sign a written release to be placed in his/her personnel file that permits the record custodian to provide, either in person, by telephone, or by mail, information specified in the release to prospective employers, educational institutions, or other persons specified in the release.
- 7) The Town Manager, with the concurrence of the Town Board, may inform any person of the employment, non-employment, promotion, demotion, suspension or other disciplinary action, reinstatement, transfer, or dismissal of a Town employee, and the reasons for that action. Before releasing that information, the Town Manager shall determine that the release is essential to maintaining the level and quality of Town services. The written determination shall be retained in the Town Manager's office, is a record for public inspection, and shall become a part of the employee's personnel file.

The Town Board shall establish procedures for all personnel files containing information other than the public information mentioned above whereby an employee who objects to material may seek to have the material removed from the file or may place in the file a statement relating to the material.

**Section 3. Personnel Actions**

The Town Manager will prescribe necessary forms and reports for all personnel actions. The Town Clerk will retain records necessary for the proper administration of the personnel system.

**Section 4. Records of Former Employees**

The provisions for access to records apply to former employees as they apply to present employees.

**Section 5. Remedies of Employees Objecting to Material in File**

An employee who objects to material in his/her file may place a statement in the file relating to the material considered to be inaccurate or misleading. The employee may seek removal of such material in accordance with established grievance procedures.

**Section 6. Penalties for Permitting Access to Confidential Records**

Section 160A-168 of the General Statutes provides that any public official or employee who knowingly and willfully permits any person to have access to any confidential information contained in an employee personnel file, except as expressly authorized by the designated custodian, is guilty of a misdemeanor and upon conviction shall be fined in an amount consistent with the General Statutes.

**Section 7. Examining or Copying Material Without Authorization**

Section 160A-168 of the General Statutes of North Carolina provides that any person, not specifically authorized to have access to a personnel file designated as confidential, who shall knowingly and willfully examine in its official filing place, remove or copy any portion of a confidential personnel file shall be guilty of a misdemeanor and upon conviction shall be fined consistent with the General Statutes.

**Section 8. Destruction of Records Regulated**

No public official may destroy, sell, loan, or otherwise dispose of any public record, except in accordance with GS 121.5, without the consent of the State Department of Cultural Resources. Whoever unlawfully removes a public record from the office where it is usually kept, or whoever alters, defaces, mutilates or destroys it will be guilty of a misdemeanor and upon conviction will be fined in an amount provided in Chapter 132.3 of the General Statutes.

**ARTICLE XII. IMPLEMENTATION OF POLICIES**

**Section 1. Conflicting Policies Repealed**

All policies, ordinances, or resolutions that conflict with the provisions of these policies are hereby repealed.

**Section 2. Separability**

If any provision of these policies or any rule, regulation, or order thereunder of the application of such provision to any person or circumstances is held invalid, the remainder of these policies and the

application of such remaining provisions of these policies of such rules, regulations, or orders to persons or circumstances other than those held invalid will not be affected thereby.

**Section 3. Effective Date**

These policies shall become effective on November 14, 2016. Amended September 9, 2019.



Attachment #4

9 September 2019

Brandon Holland, Manager  
Town of Biscoe  
110 W. Main St.  
Biscoe, NC 27209

Re: RFP-Legal Services/Sanitary Sewer System Rehabilitation

Dear Mr. Holland:

I have reviewed the Town's request for proposals for legal services regarding the sanitary sewer system rehabilitation project. I hope that this letter will serve as my firm's submission in response to the Town's request.

Hollers & Atkinson, P.C. is a professional corporation with its office in Troy. The mailing address, e-mail address, and telephone and fax numbers are found on the letterhead above.

I am the principal of the law firm. I have been a licensed attorney in North Carolina since August 1992 and have been in practice continuously since that date. The firm's current practice is focused on real estate transactions, local government counseling, and wills/estate administration.

The firm currently represents the County of Montgomery, the Town of Candor, the Town of Troy, and the Town of Biscoe. I have represented those local governments since the retirement of the partners of the predecessor firm, Hollers & Atkinson, Attorneys at Law, in December 2016. The predecessor firm represented those clients, except for the Town of Biscoe, for decades before the succession of the current firm in January 2017. References would be Matthew Woodard (County Manager), Greg Zephir (Town of Troy Manager), and Tammy Kellis (Town of Candor Clerk).

The requested legal services are consistent with the current focus of the firm's practice. We are capable of completing the legal work since it will fit into the flow of our practice. I do not anticipate any particular block of time that the firm will be unavailable during the project.

The fee for legal services will be \$175.00 per hour for attorney time and \$35.00 per hour for paralegal/clerk time. The hourly rate for legal services is my normal rate for local government work and is approximately 25% lower than my rate for similar legal work. I will advance recording costs, excise tax stamp fees, and other miscellaneous costs and bill the Town afterwards at no markup. If I have to travel, I will bill the Town at my hourly rate but will not charge for mileage.

I have attached a printout from the North Carolina State Bar that shows my eligibility to practice law in the state.

Please call me if you have any questions or desire more information. I thank you in advance for your time and consideration and remain,

Sincerely yours,

Russell J. Hollers, III

Attachment #5

**TOWN OF BISCOE**  
**BOARD OF COMMISSIONERS MEETING**  
**September 25, 2019**

The Biscoe Town Board of Commissioners met in a special called meeting on Wednesday, September 25, 2019 at noon in the Municipal Building. Present were: Mayor Jimmy Blake, Commissioners Gene Anderson, and John Beard (via telephone).

(James Cagle, Jr. "Jimmy" Cagle's seat is vacant due to his death on December 30, 2017).

Absent: Mayor Pro-Tem Jerry Smith, Kay Cagle Kinch

*Members of Management Present: Town Manager Brandon Holland, Town Clerk Laura Morton, Public Works Director Sam Stewart and Police Chief Shane Armstrong.*

**Approval of AIA Grant Application Resolution**

---

A motion was made by Commissioner Beard, seconded by Commissioner Anderson, and so the motion carried unanimously to approve the AIA Grant Application Resolution as presented.

**Approval to Receive the Allen Property Road into the Cemetery**

---

A motion was made by Commissioner Anderson, seconded by Commissioner Beard, and so the motion carried unanimously to accept the road leading to the cemetery from the Jeff Allen family.

(This road will need to be annexed into the Town before it can be added to the Powell Bill Street Listing.)

**Adjournment**

---

There being no further business to bring before the Board, Commissioner Beard made the motion to adjourn, and Commissioner Anderson made the second. All voted in favor. Meeting adjourned at 12:15 pm.

\_\_\_\_\_  
Mayor



\_\_\_\_\_  
Town Clerk

**TOWN OF BISCOE**  
**BOARD OF COMMISSIONERS MEETING**  
**June 10, 2019**

The Biscoe Town Board of Commissioners met in a regular session on Monday, June 10, 2019 at 7:00 pm in the Municipal Building. Present were: Mayor Jimmy Blake, Mayor Pro-Tem Jerry Smith, Commissioners Gene Anderson, Kay Cagle Kinch and John Beard. (James Cagle, Jr. "Jimmy" Cagle's seat is vacant due to his death on December 30, 2017).

*Members of Management Present: Town Manager Brandon Holland, Town Clerk Laura Morton, and Police Chief Brent Tedder.*

**Call to Order/Pledge of Allegiance**

---

Mayor Blake called the meeting to order at 7:00 pm. The Pledge of Allegiance to the American Flag was recited and a moment of silence was observed.

**Conflict of Interest Statement**

---

"In keeping with the Conflict of Interest Laws outlined in Chapter 138A of the North Carolina Board of Ethics, any conflicts of interest or appearance of conflict with matters coming before the Board of Commissioners should be declared," "Having received our agenda for this evening's meeting, are there any conflicts of interest to be announced? If so, please, state them at this time."

**Approval of the Consent Agenda**

---

*A motion was made by Mayor Pro-tem Smith, seconded by Commissioner Beard and so the motion carried unanimously to approve consent agenda items:*

- a) Approval of the Agenda
- b) Approval of May 13, 2019 Regular Meeting Minutes
- c) Approval of June Monthly Financial Report
- d) Approval of Pool Concession Fees
- e) Approval of Policy to Unseal Closed Session Minutes

*AYES: 4; NAYS: 0*

**Schedule Public Hearing #1 – Proposed Fiscal Year 2019-2020 Budget**

---

A motion was made by Commissioner Anderson, seconded by Commissioner Kinch, and so the motion carried unanimously to set a Public Hearing for June 10, 2019 for the Proposed Fiscal Year 2019-2020 Budget.

*AYES: 4; NAYS: 0*

**Schedule Public Hearing #1 – Proposed Fire Hydrant Policy**

---

A motion was made by Commissioner Beard, seconded by Mayor Pro-tem Smith, and so the motion carried unanimously to set a Public Hearing for June 10, 2019 for the Proposed Fire Hydrant Policy.

*AYES: 4; NAYS: 0*

**Reconsideration of Game Room Application for Demetrius Stancil**

---

Manager Holland

**Proposed Water/Sewer Ordinance Amendment**

---

Laura Jordan, Deputy Clerk

**Budget Amendment Request – Pump Replacement      Manager Holland**

---

**Mayor’s Minutes   -   Commissioner Reports   -   Staff Reports**

*The Mayor said he would be taking Charlie Gaddy on a tour on Wednesday.*

**Public Comment**

---

No one spoke during the public forum.

**Closed Session- Pursuant to NCGS 143-318.11 (5) - Property & NCGS 143-318.11 (6) Personnel**

---

A motion was made by Mayor Pro-tem Smith, seconded by Commissioner Kinch, and so the motion carried unanimously to recess the regular meeting and call to order a Closed Session – Pursuant to NCGS 143-318.11 (5) – Property and NCGS 143-318.11 (6) - Personnel.

*AYES: 4; NAYS: 0*

A motion was made by Commissioner Beard, seconded by Mayor Pro-tem Smith, and so the motion carried unanimously to adjourn the closed session and reconvene the regular meeting.

*AYES: 4; NAYS: 0*

The Board came out of the Public Hearing with nothing to report.

**Adjournment**

There being no further business to bring before the Board, Commissioner Beard made the motion to adjourn, and Mayor Pro-tem Smith made the second. All voted in favor. Meeting adjourned at 8:00 p.m.

---

Mayor



---

Town Clerk

# BISCOE MONTHLY FINANCIAL REPORT

FIRST BANK ACCOUNTS 2019 MONTHLY FINANCIAL REPORT			
ACCOUNT	INTEREST RATE	BALANCE	STATUS
MONEY MARKET - Bank 3	.05%	\$1,423,710.97	RECONCILED THRU August 31, 2019
GENERAL FUND 10 – CD 54 - Bank 102	.15%	\$237,228.25	RECONCILED THRU September 30, 2019
FUND 21 – CAP. RES. CD 49 - Bank 104	ACCOUNT CLOSED PER MARCH 2019 APPROVAL & A NEW NCCMT ACCT OPENED		
FUND 72 LEO – CD 30 - Bank 105	ACCOUNT CLOSED PER MARCH 2019 APPROVAL & A NEW NCCMT ACCT OPENED		
<b>TOTAL FIRST BANK ACCOUNTS</b>		<b><u>\$1,664,977.22</u></b>	

FIDELITY BANK ACCOUNTS 2019 MONTHLY FINANCIAL REPORT			
ACCOUNT	INTEREST RATE	BALANCE	STATUS
CENTRAL DEPOSITORY - Bank 1	.10%	\$988,088.64	RECONCILED THRU September 30, 2019
PAYROLL ACCOUNT - Bank 4	.10%	\$98,088.64	RECONCILED THRU September 30, 2019
NATIONAL NIGHT OUT **NEW Bank 120	.03%	\$452.56	RECONCILED THRU September 30, 2019
CDBG-I BRUTON STREET **NEW Bank 119	.50%	\$126,307.61	RECONCILED THRU September 30, 2019
<b>TOTAL FIDELITY BANK ACCOUNTS</b>		<b><u>\$1,212,937.45</u></b>	

2019 NC CAPITAL MANAGEMENT TRUST INVESTMENT ACCOUNTS			
ACCOUNT	INTEREST RATE	BALANCE	STATUS
NC DEBT SET-OFF GOVT - Bank 108 FUND 60	2.05%	\$11,026.85	RECONCILED THRU September 30, 2019
PAYROLL (GF) GOVT. - Bank 112 FUND 10	2.05%	\$104,048.00	RECONCILED THRU September 30, 2019
POWELL BILL ACCOUNT – GOVT. - Bank 116 FUND 11	2.05%	\$115,328.13	RECONCILED THRU September 30, 2019
CAPITAL RESERVE – GOVT. Bank 121 *New Account - FUND 21	2.05%	\$34,925.77	RECONCILED THRU September 30, 2019
LEO SEPARATION ALLOWANCE - GOVT Bank 122 *New Account FUND 72	2.05%	\$28,575.51	RECONCILED THRU September 30, 2019
CEMETERY (GF) TERM - Bank 113 FUND 10	2.21%	\$52,337.68	RECONCILED THRU September 30, 2019
HALLOWEEN IN THE PARK (GF) TERM Bank 114 FUND 10	2.21%	\$26,167.53	RECONCILED THRU September 30, 2019
GENERAL NEEDS (GF) TERM - Bank 115 FUND 10	2.21%	\$225,808.21	RECONCILED THRU September 30, 2019
WATER IMP. (WS) TERM Bank 111 FUND 60	2.21%	\$52,832.99	RECONCILED THRU September 30, 2019
<b>TOTAL NCCMT INVESTMENT ACCOUNTS</b>		<b><u>\$651,050.67</u></b>	

**Please Note In Addition to the Above Bank Accounts, Town Clerk/Finance Officer Reconciles  
The Following Accounts Each Month for Biscoe Fire Department.**

<b>FIRE DEPARTMENT - 2019 MONTHLY FINANCIAL REPORT</b>			
<b>ACCOUNT</b>	<b>INTEREST RATE</b>	<b>BALANCE</b>	<b>STATUS</b>
BISCOE FIRE DEPARTMENT (checking) FIRST BANK - Bank 101	.10%	\$126,692.40	<i>RECONCILED THRU September 30, 2019</i>
BISCOE FIRE RELIEF FUND FIRST BANK - Bank 109	.10%	\$16,623.78	<i>RECONCILED THRU September 30, 2019</i>
BISCOE FIRE STATE RELIEF FUND FIDELITY BANK – restricted - Bank 110	.05%	\$2,050.54	<i>RECONCILED THRU September 30, 2019</i>
BISCOE FIRE DEPT CD FIDELITY BANK - Bank 117	.15%	\$34,940.93	<i>RECONCILED THRU September 30, 2019</i>
BISCOE FIRE DEPT SUPPLEMENTAL RETIREMENT ACCT. – restricted - Bank 118	.12%	\$51,084.31	<i>RECONCILED THRU September 30, 2019</i>
<b>TOTAL FIRST BANK &amp; FIDELITY BANK ACCOUNTS</b>		<b><u>\$231,391.96</u></b>	

**NCCMT RATES CONTINUE TO INCREASE**  
**RATES AS OF 10.05.2019**  
 Rates for Government Portfolio Increased from **1.96**  
 Rates for Term Portfolio Increased from **2.02**

---

**SEWER ACROSS THE BYPASS**

Golden Leaf Funds – (Grant no pay back) - \$800,000.00  
 Town Funds - \$1,458,960.00  
 Total Project - \$2,258,960.00

---

**WASTEWATER TREATMENT PLANT**

Clean Water Management Trust Fund Grant \$ 584,000.00  
 State Revolving Loan – Interest Rate 0.00% \$1,323,106.00 Annual Payment of \$66,155.30.  
 This FY Payment was made on April 12, 2019  
 As of June 30, 2018, the Town owes approximately \$1,124,640.10. (To Be Paid Off May 1, 2036)

The annual payment is \$66,155.30. The next payment annual payment will be made in May of 2019. This will leave a balance of \$1,124,640.10. Total Project - \$1,190,795.40

---

**INDUSTRIAL PUMP STATION - FIRST BANK**

First Bank Commercial Loan – Interest Rate 1.75% Loan Total \$350,000.00  
 Last payment of \$6,198.91 posted on September 30, 2019, the Town owes approximately \$73,687.94.

---

**LADDER TRUCK LOAN – FIDELITY BANK**

Fidelity Bank Commercial Loan – Interest Rate 3.75% Loan/Principal Total \$175,000.00 Annual Payment Amount: \$21,366.91.  
 First Payment was made on June 14, 2019. Balance \$160,286.74. Loan is for 10 years. To be Paid in full May of 2028.

---

**BRUTON STREET PUMP STATION**

The Town of Biscoe has received a grant award of \$1,865,000 for their CDBG Infrastructure Application for the “Sanitary Sewer System Rehabilitation” project. The RFP for Administrative Services was awarded to LKC Engineering. Monthly progress meetings began in June of 2019.

## SALES & USE TAX RECEIVED

### BUDGET CODE - 10-3230-000

JULY 2019 .....	\$38,222.59
AUGUST 2019.....	\$40,172.77
SEPTEMBER 2019 .....	\$41,742.37
OCTOBER 2019 .....	
NOVEMBER 2019 .....	
DECEMBER 2019 .....	
JANUARY 2020 .....	
FEBRUARY 2020 .....	
MARCH 2020 .....	
APRIL 2020 .....	
MAY 2020.....	
JUNE 2020 .....	
TOTAL RECEIVED AS OF DATE ABOVE .....	<u>\$120,137.73</u>

## SOLID WASTE DISPOSAL TAX RECEIVED

### BUDGET CODE - 10-3270-000

AUGUST 2019.....	\$ 310.93
NOVEMBER 2019 .....	
FEBRUARY 2020 .....	
MAY 2020.....	
JUNE 2020 .....	
TOTAL RECEIVED AS OF DATE ABOVE .....	<u>\$310.93</u>

## TAX PAYMENTS RECEIVED

### (Property & Vehicle Tax)

*Tax Payments from Montgomery County Tax Department have been received*

JULY 2019 .....	\$ 6,221.19
AUGUST 2019.....	\$ 60,399.85
SEPTEMBER 2019 .....	
OCTOBER 2019 .....	
NOVEMBER 2019 .....	
DECEMBER 2019 .....	
JANUARY 2020 .....	
FEBRUARY 2020 .....	
MARCH 2020 .....	
APRIL 2020 .....	
MAY 2020.....	
JUNE 2020 .....	
TOTAL RECEIVED AS OF DATE ABOVE .....	<u>\$ 66,621.04</u>



**TELECOM SALES TAX RECEIVED**

**BUDGET CODE - 10-3224-350**

AUGUST 2019.....	\$1,993.71
NOVEMBER 2019 .....	
FEBRUARY 2020 .....	
MAY 2020.....	
JUNE 2020 .....	
TOTAL RECEIVED AS OF DATE ABOVE .....	<u>\$1,993.71</u>

**UNAUTHORIZED SUBSTANCE ABUSE TAX RECEIVED**

**BUDGET CODE - 10-3431-890**

AUGUST 2019.....	\$ 442.13
NOVEMBER 2019 .....	
FEBRUARY 2020 .....	
MAY 2020.....	
JUNE 2020 .....	
TOTAL RECEIVED AS OF DATE ABOVE .....	<u>\$ 442.13</u>

**UTILITY FRANCHISE TAX RECEIVED**

**BUDGET CODE - 10-3224-000**

AUGUST 2019.....	\$ 54,900.12
NOVEMBER 2019 .....	
FEBRUARY 2020 .....	
MAY 2020.....	
JUNE 2020 .....	
TOTAL RECEIVED AS OF DATE ABOVE .....	<u>\$ 54,900.12</u>

**VIDEO PROGRAMMING TAX RECEIVED**

**BUDGET CODE - 10-3224-350**

AUGUST 2019.....	\$ 1,189.85
NOVEMBER 2019 .....	
FEBRUARY 2020 .....	
MAY 2020.....	
JUNE 2020 .....	
TOTAL RECEIVED AS OF DATE ABOVE .....	<u>\$ 1,189.85</u>

TOWN OF BISCOE, NC  
100,000 GALLON ELEVATED

OPTION B  
SHOP TANK

WATER TANK MAINTENANCE SCHEDULE OF WORK & FEES

Year #1 2016	Year #2 2017	Year #3 2018	Year #4 2019	Year #5 2020	Year #6 2021	Year #7 2022	Year #8 2023	Year #9 2024	Year #10 2025	Year #11 2026	Year #12 2027	Year #13 2028	Year #14 2029
Exterior Lead Abatement & Interior Renovation & Engineering Report	Visual Inspection & Engineering Report	Washout Inspection & Engineering Report	Visual Inspection & Engineering Report	Washout Inspection & Engineering Report	Visual Inspection & Engineering Report	Washout Inspection & Engineering Report	Visual Inspection & Engineering Report	Washout Inspection & Engineering Report	Exterior Renovation & Engineering Report	Washout Inspection & Engineering Report	Visual Inspection & Engineering Report	Washout Inspection & Engineering Report	Interior Renovation & Engineering Report
\$30,000.00	\$57,891.00	\$57,891.00	\$57,891.00	\$57,891.00	\$10,968.00	\$11,288.00	\$11,687.00	\$12,101.00	\$12,529.00	\$812,968.00	\$13,422.00	\$13892.00	\$14,379.00

- \* Under the Asset Management Service, the tank is painted on the exterior every 8-10 years and coated on the interior every 12 to 14 years. The annual fee that you pay each year covers all future renovations, repairs, emergency services, and engineering & permitting related to the water tank.
- \* The schedule of work is based upon the current condition of the tank and the tank's projected rate of deterioration and can be pushed forward if conditions warrant it.
- \*\*\* Asset Management Service Includes:
  - Two (2) Complete Interior Renovations
  - Two (2) Complete Exterior Renovations
  - Five (6) Washout Engineering Inspections
  - Five (5) Visual Engineering Inspections
  - All coating systems, emergency services, and repairs from top of vent system down to the leg foundation and everything in between is covered under this program.

## **Reports Completed** *(In addition to monthly bank reconciliations)*

---

### **1<sup>st</sup> Quarter: March 2019**

- 941
- NC 5Q
- Employment Security Commission
- NCDOR E-500 (Pool Concessions)
- 2nd Quarter: March 2019 941, NC 5Q, Employment Security Commission, NCDOR E-500 (Pool Concessions)
- LGC-203 Cash & Investments Report for Reporting Period ending December 31, 2018
- LEO Separation Allowance Actuarial Study Report
- US Government's System for Award Management – for DUNS Number – Annual Update
- FEMA Reports due to Hurricane Florence
- GMS and GPRS – Office of Justice Programs Annual Update

### **2nd Quarter: June 2019**

- 941
- NC 5Q
- Employment Security Commission
- NCDOR E-500 (Pool Concessions)
- 2nd Quarter: March 2019 941, NC 5Q, Employment Security Commission, NCDOR E-500 (Pool Concessions)
- LGC-203 Cash & Investments Report for Reporting Period ending June 30, 2019
- COLL-91 Report Form – Annual Notification by Public Depositor
- NC Department of Labor Public Sector OSH Injury & Illness Survey
- Powell Bill Certified Statement, Street Listing, Certified Powell Bill Map
- Powell Bill Expenditure Report
- Equitable Sharing Expenditure Report
- CCR Annual Report Mailing
- NC Demographic Information Survey for NC Office of State Budget and Management
- Secretary of State Board Appointment Report Due September 1, 2019 – Completed
- NCDOR –E585 Sales & Use Refund Request for Sales Tax Paid July 1, 2018 thru June 30, 2019 Submitted

### ***3rd Quarter: September 2019***

- 2018-19 Worker's Comp Self Audit due August 28, 2019.
- Uploaded all auditor requests to their audit portal.
- Pulled test samples requested by auditors
- Procedural Walk-through with auditors
- Helped 2 employees with FMLA and short term disability
- Attended Clerks Conference in Wilkesboro NC
- Worked on new policies: Surplus Property and Suggested Rules of Procedure for Town Council
- Worked on updating the Personnel Policy
- Worked on various CDBG items
- Attended Fair Housing Workshop
- Opened new Fire Department Account at First Bank for County Fire Funds
- Updated the Website
- Created pictures for Social Media
- Held Monthly Administration Staff Meeting
- Swore in new Police Officer Zuniga. Signed him up.
- Distributed Payment to LKC for CDBG-I Bruton Street Project
- Worked with Contractor for work in Copy Room
- Scanned and checked all Cemetery Records
- Reviewed all weekly check runs
- Reviewed and confirm daily receipts
- Posted all NC E-Pay Deposits
- NCDOR E-500 (Pool Concessions) (To be done week of October 14)
- 3rd Quarter: September 2019 941, NC 5Q, Employment Security Commission, NCDOR E-500 (Pool Concessions)
- Created "Personnel Page" on the Town Website
- Created NEW ordinance book, resolution book, policy book, proclamation book
- Planned upcoming events (Bingo, Employee Appreciation Luncheon, etc.)
- Went to Hobby Lobby to have pictures framed (Mayor and other historical frames)

### ***4th Quarter: December 2019***

# OATH OF OFFICE

*"I, Timothy Shane Armstrong, do solemnly swear (or affirm) that I will support and maintain the Constitution and laws of the United States, and the Constitution and laws of North Carolina not inconsistent therewith, and that I will faithfully discharge the duties of my office as Police Chief, so help me God."*

\_\_\_\_\_  
Date

\_\_\_\_\_  
Timothy Shane Armstrong

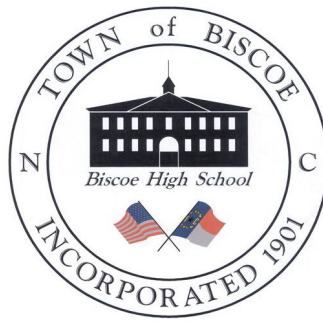

\_\_\_\_\_  
Date

\_\_\_\_\_  
Laura B. Morton, Town Clerk

## **Annexation of New Road**

The Jeff Allen Family has given the Town the road into the cemetery. Town Clerk Laura Morton has received the deed and survey map (included in your agenda packet).

I have also included an Annexation Checklist. This meeting is the first step in the process.

*The Board will need the following motion:*

To direct the Town Clerk to complete a Certificate of Sufficiency and to schedule a public hearing for the November 11, 2019 meeting.

Gaw

2



This document presented and filed:  
09/26/2019 04:49:21 PM

Melissa F. Pipkin, Montgomery County, NC  
REAL ESTATE EXCISE TAX: \$0.00

\$ 26,000

Excise Tax: -0-  
Prepared by: Gamer & Williamson, P.A., Attorneys, 111 Courthouse Square, Troy, NC 27371.  
Brief Description for Index: New Lot C  
Tax Parcel Number:  
**NO TITLE EXAM**

STATE OF NORTH CAROLINA

COUNTY OF MONTGOMERY

GENERAL WARRANTY DEED

THIS DEED made this the 18th day of September 2019 by and between

GRANTOR	GRANTEE
TRIPLE A ENTERPRISES, INC.	TOWN OF BISCOE
(Does Not Include Primary Residence)	110 W. Main Street Biscoe, NC 27209

The designation GRANTOR and GRANTEE as used herein shall include said parties, their heirs, successors, and assigns, and shall include singular, plural, masculine, feminine or neuter as required by context.

WITNESSETH, that the GRANTOR, for a valuable consideration paid by the GRANTEE, the receipt of which is hereby acknowledged, has and by these presents does grant, bargain, sell and convey in fee simple absolute in that property being more particularly described as follows:

**BEING New Lot C, containing 0.406 acres more or less, and being access to the Town of Biscoe Cemetery, as shown on plat recorded in Plat Cabinet G, Slide 79-D, incorporated herein by reference, subject to use of the road by purchasers of New Lot B and New Lot A.**

For title reference see Book 298, Page 833, Montgomery County Registry.

TO HAVE AND TO HOLD the aforesaid lot or parcel of land and all privileges and appurtenances thereto belonging to the GRANTEE in fee simple.

And the GRANTOR covenants with the GRANTEE, that GRANTOR is seized of the premises in fee, that title is marketable, free from encumbrances and that he will warrant and defend said title against the lawful claims of all persons.

IN WITNESS WHEREOF, the GRANTOR have hereunto set their hands and seals this the day and year first above written.

TRIPLE A ENTERPRISES, INC.  
*[Signature]* *President* SEAL  
By Franklin Ray Allen, President

STATE OF NORTH CAROLINA

COUNTY OF MONTGOMERY

I, a Notary Public in and for said County and State, do hereby certify that Franklin Ray Allen personally appeared before me this day and acknowledged that he President of TRIPLE A ENTERPRISES, INC. a NC corporation and that, by authority duly given and as the act of the corporation, the foregoing instrument was signed in its name by its President.

Witness my hand and notarial seal, this the 26 day of September 2019.

*[Signature]*  
NOTARY PUBLIC

My Commission Expires: 4-26-21





STATE OF NORTH CAROLINA  
 COUNTY OF MONTGOMERY  
 CERTIFICATE OF APPROVAL FOR RECORDING  
 I, JO HENRY GIBBS, CLERK OF SUPERIOR COURT, do hereby certify that the within plat has been duly recorded in the Public Records Office of the County of Montgomery, North Carolina, on this 11th day of September, 2019, at 11:32am.

RECORDED BY: *[Signature]*  
 DATE: 9-11-2019  
 REC'D: 11:32am

No other fees have been paid as a part of this recording process, and the recording fee has been paid in full. The recording fee is a public record and is available for public inspection. For information regarding this recording process, please contact the appropriate agency. This document is subject to the provisions of the Public Records Act, which provides that any person may request a copy of this document and receive it in accordance with the provisions of that Act.

LINE LEGEND  
 PROPERTY LINE SURVEYED  
 PROPERTY LINE NOT SURVEYED  
 ADJACENT PROPERTY LINE  
 STATE RIGHT OF WAY  
 ROAD LINE  
 LINE OF GRAVE

ST-6-79D  
 9-11-2019  
 11:32am  
 Salgado

CERTIFICATE OF APPROVAL FOR RECORDING  
 I, JO HENRY GIBBS, CLERK OF SUPERIOR COURT, do hereby certify that the within plat has been duly recorded in the Public Records Office of the County of Montgomery, North Carolina, on this 11th day of September, 2019, at 11:32am.

RECORDED BY: *[Signature]*  
 DATE: 9-11-2019  
 REC'D: 11:32am

No other fees have been paid as a part of this recording process, and the recording fee has been paid in full. The recording fee is a public record and is available for public inspection. For information regarding this recording process, please contact the appropriate agency. This document is subject to the provisions of the Public Records Act, which provides that any person may request a copy of this document and receive it in accordance with the provisions of that Act.

LINE LEGEND  
 PROPERTY LINE SURVEYED  
 PROPERTY LINE NOT SURVEYED  
 ADJACENT PROPERTY LINE  
 STATE RIGHT OF WAY  
 ROAD LINE  
 LINE OF GRAVE

CERTIFICATE OF APPROVAL FOR RECORDING  
 I, JO HENRY GIBBS, CLERK OF SUPERIOR COURT, do hereby certify that the within plat has been duly recorded in the Public Records Office of the County of Montgomery, North Carolina, on this 11th day of September, 2019, at 11:32am.

RECORDED BY: *[Signature]*  
 DATE: 9-11-2019  
 REC'D: 11:32am

No other fees have been paid as a part of this recording process, and the recording fee has been paid in full. The recording fee is a public record and is available for public inspection. For information regarding this recording process, please contact the appropriate agency. This document is subject to the provisions of the Public Records Act, which provides that any person may request a copy of this document and receive it in accordance with the provisions of that Act.

LINE LEGEND  
 PROPERTY LINE SURVEYED  
 PROPERTY LINE NOT SURVEYED  
 ADJACENT PROPERTY LINE  
 STATE RIGHT OF WAY  
 ROAD LINE  
 LINE OF GRAVE

CERTIFICATE OF APPROVAL FOR RECORDING  
 I, JO HENRY GIBBS, CLERK OF SUPERIOR COURT, do hereby certify that the within plat has been duly recorded in the Public Records Office of the County of Montgomery, North Carolina, on this 11th day of September, 2019, at 11:32am.

RECORDED BY: *[Signature]*  
 DATE: 9-11-2019  
 REC'D: 11:32am

No other fees have been paid as a part of this recording process, and the recording fee has been paid in full. The recording fee is a public record and is available for public inspection. For information regarding this recording process, please contact the appropriate agency. This document is subject to the provisions of the Public Records Act, which provides that any person may request a copy of this document and receive it in accordance with the provisions of that Act.

LINE LEGEND  
 PROPERTY LINE SURVEYED  
 PROPERTY LINE NOT SURVEYED  
 ADJACENT PROPERTY LINE  
 STATE RIGHT OF WAY  
 ROAD LINE  
 LINE OF GRAVE

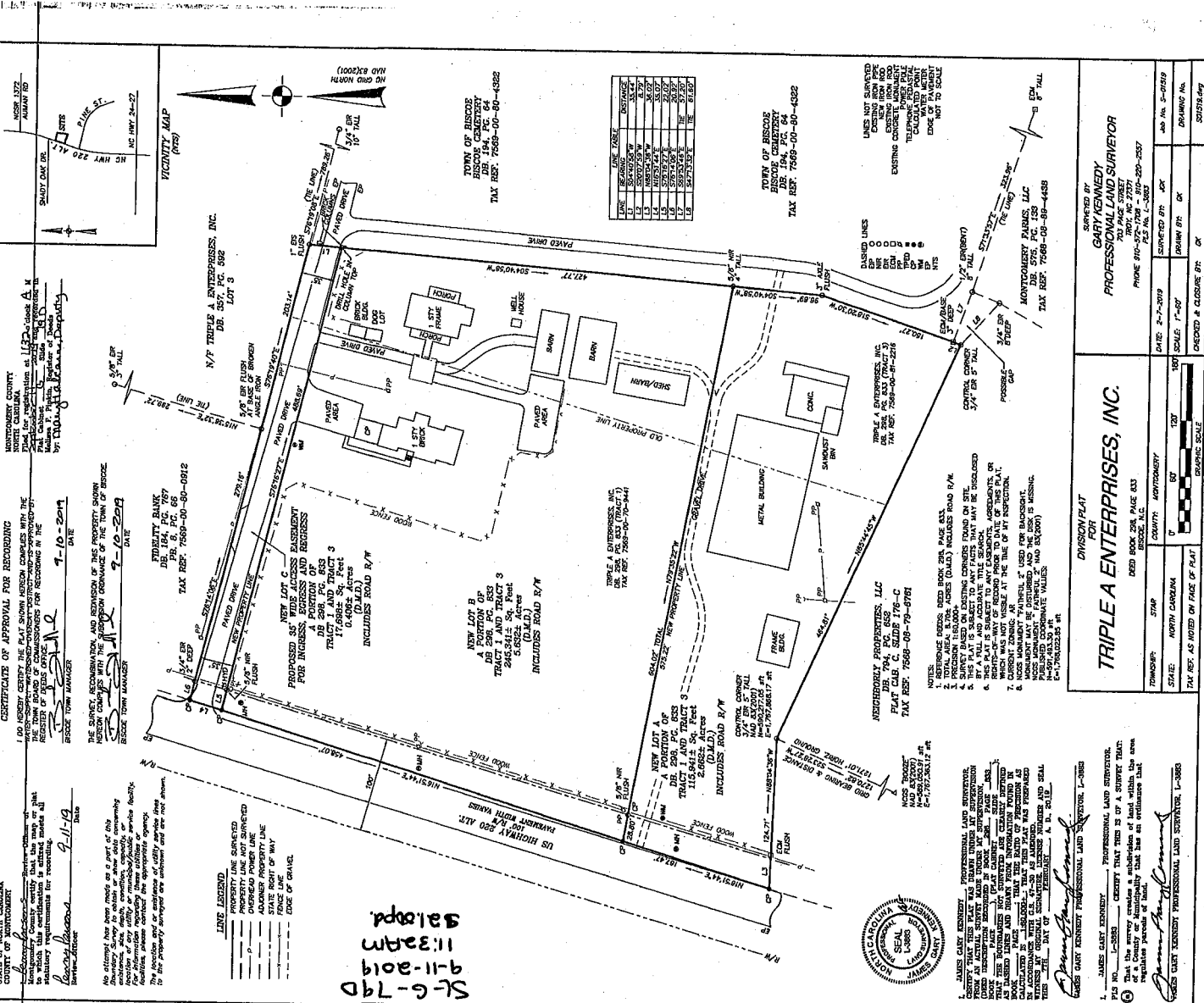

LINE	BEARING	DISTANCE
L1	S89°02'58"W	33.77
L2	S00°00'00"W	33.00
L3	N00°00'00"W	33.00
L4	S00°00'00"W	33.00
L5	S00°00'00"W	33.00
L6	S00°00'00"W	33.00
L7	S00°00'00"W	33.00
L8	S00°00'00"W	33.00
L9	S00°00'00"W	33.00
L10	S00°00'00"W	33.00

TOWN OF RISSON  
 DISCOLE CEMETERY  
 DR. 194, P.C. 64  
 TAX REF. 7609-00-90-4322

TOWN OF RISSON  
 DISCOLE CEMETERY  
 DR. 194, P.C. 64  
 TAX REF. 7609-00-90-4322

TOWN OF RISSON  
 DISCOLE CEMETERY  
 DR. 194, P.C. 64  
 TAX REF. 7609-00-90-4322

TOWN OF RISSON  
 DISCOLE CEMETERY  
 DR. 194, P.C. 64  
 TAX REF. 7609-00-90-4322

TOWN OF RISSON  
 DISCOLE CEMETERY  
 DR. 194, P.C. 64  
 TAX REF. 7609-00-90-4322

TOWN OF RISSON  
 DISCOLE CEMETERY  
 DR. 194, P.C. 64  
 TAX REF. 7609-00-90-4322

TOWN OF RISSON  
 DISCOLE CEMETERY  
 DR. 194, P.C. 64  
 TAX REF. 7609-00-90-4322

TOWN OF RISSON  
 DISCOLE CEMETERY  
 DR. 194, P.C. 64  
 TAX REF. 7609-00-90-4322

TOWN OF RISSON  
 DISCOLE CEMETERY  
 DR. 194, P.C. 64  
 TAX REF. 7609-00-90-4322

TOWN OF RISSON  
 DISCOLE CEMETERY  
 DR. 194, P.C. 64  
 TAX REF. 7609-00-90-4322

TOWN OF RISSON  
 DISCOLE CEMETERY  
 DR. 194, P.C. 64  
 TAX REF. 7609-00-90-4322

TOWN OF RISSON  
 DISCOLE CEMETERY  
 DR. 194, P.C. 64  
 TAX REF. 7609-00-90-4322

TOWN OF RISSON  
 DISCOLE CEMETERY  
 DR. 194, P.C. 64  
 TAX REF. 7609-00-90-4322

TOWN OF RISSON  
 DISCOLE CEMETERY  
 DR. 194, P.C. 64  
 TAX REF. 7609-00-90-4322

TOWN OF RISSON  
 DISCOLE CEMETERY  
 DR. 194, P.C. 64  
 TAX REF. 7609-00-90-4322

TOWN OF RISSON  
 DISCOLE CEMETERY  
 DR. 194, P.C. 64  
 TAX REF. 7609-00-90-4322

TOWN OF RISSON  
 DISCOLE CEMETERY  
 DR. 194, P.C. 64  
 TAX REF. 7609-00-90-4322

TOWN OF RISSON  
 DISCOLE CEMETERY  
 DR. 194, P.C. 64  
 TAX REF. 7609-00-90-4322

TOWN OF RISSON  
 DISCOLE CEMETERY  
 DR. 194, P.C. 64  
 TAX REF. 7609-00-90-4322

TOWN OF RISSON  
 DISCOLE CEMETERY  
 DR. 194, P.C. 64  
 TAX REF. 7609-00-90-4322

TOWN OF RISSON  
 DISCOLE CEMETERY  
 DR. 194, P.C. 64  
 TAX REF. 7609-00-90-4322

TOWN OF RISSON  
 DISCOLE CEMETERY  
 DR. 194, P.C. 64  
 TAX REF. 7609-00-90-4322

TOWN OF RISSON  
 DISCOLE CEMETERY  
 DR. 194, P.C. 64  
 TAX REF. 7609-00-90-4322

SEAL OF THE PROFESSIONAL LAND SURVEYOR

DATE: 9-11-2019  
 SCALE: 1"=50'  
 CHECKED & CLOSED BY: DK  
 DRAWN BY: DK  
 SURVEYED BY: DK  
 JOB NO. S-0959  
 DRAWING NO. 002194.dwg

FOR  
**TRIPLE A ENTERPRISES, INC.**  
 700 W. 200th St.  
 RISSON, NC 27582

DESIGNED BY: GARY KENNEDY  
 PROFESSIONAL LAND SURVEYOR  
 700 W. 200th St.  
 RISSON, NC 27582  
 PHONE 910-972-708 - 501-220-2337  
 PLS. NO. L-3683

DATE: 9-11-2019  
 SCALE: 1"=50'  
 CHECKED & CLOSED BY: DK  
 DRAWN BY: DK  
 SURVEYED BY: DK  
 JOB NO. S-0959  
 DRAWING NO. 002194.dwg

## ANNEXATION CHECKLIST

---

- Voluntary Annexation Petition
  - Plat Map
  - Legal Description of Property
  - Deed
  - Fee
- Certificate of Sufficiency STEP 1
- Notice of Public Hearing
- Affidavit of Publication for Public Hearing
- Ordinance/Resolution Stating the Intent of the Town of Biscoe to Annex Property
- Copies Filed
  - Copy of ordinance, certified minutes, map to the Secretary of State
  - Copy of ordinance, certified minutes, map to State Planner
  - Copy of ordinance, certified minutes, map to NC Department of Transportation
  - Copy of ordinance, certified minutes, map to County Planner
  - Copy of ordinance, certified minutes, map to Register of Deeds
  - Copy of ordinance, certified minutes, map to Tax Department
  - Copy of ordinance, certified minutes, map to Board of Elections
  - Copy of ordinance, certified minutes, map to Power company
  - Copy of ordinance, certified minutes, map to Telephone company
  - Copy of ordinance, certified minutes, map to Time Warner Cable
  - Copy of ordinance, certified minutes, map to Garbage company
- Letter of Receipt and Acceptance from the Secretary of State

	DATE
Recorded: Register of Deeds	
Filed with Secretary of State	
Filed with State Planner	
Filed with NCDOT	
Filed with County Planner	
Filed with Tax Department	
Filed with Board of Elections	
Filed with Power Company	
Filed with Telephone Company	
Filed with Time Warner Cable	
Filed with Garbage Company	

### **Example of a Schedule for Annexation**

---

- ## Adopt Resolution of Intent
- ## Advertise Notice of Public Hearing  
Post Notice in Three Public Places In Town
- ## Public Hearing  
Adopt Ordinance
- ## Publish Notice of Adoption

## **Approval of Bid Proposals for the Shady Oak Pump Station**

---

During Hurricane Florence in September of 2018, the Shady Oak Pump Station was damaged. After meetings with FEMA we were told we would need to send out Request for Proposals for the repairs/maintenance of the pump station.

We received bids and they are included in the agenda packet.



2000 Boone Trail Rd.  
Sanford, NC 27330

Charles R. Underwood, Inc.

Ph: 919-775-2463  
Fax: 919-708-7232

Mr. Brandon Holland  
Town of Biscoe  
110 W. Main St.  
Biscoe, NC 27209

RE: Shady Oak Pump Station – Building Replacement Improvements

Mr. Holland,

We are pleased to provide you with this proposal for building replacement improvements to Shady Oak Pump Station, per the provided RFP. Charles R. Underwood, Inc. specializes in Lift Station installations, upgrades, repairs and maintenance. We are confident the Town of Biscoe will be pleased with the result of this work, if we are awarded the project. For clarification we are providing this Scope of Work to accompany our Bid. The price provided below includes the following Scope of Work:

- Excavate and expose force main.
- Drain back force main into wet well and maintain flows with septic hauler.
- Cut in main isolation valve and bypass connection with secondary isolation valve.
  - We will utilize megalug restrained fittings and AWWA gate valves.
  - Backfill and compact forcemain and bypass connection.
- Provide duplex diesel bypass pumping system for remainder of project to run station.
  - Both pumps will be float operated.
  - Primary pump will be critically silenced considering the proximity to residents.
- Demo existing building and electrical back down to the existing concrete slab.
  - SCADA panel and manual transfer switch will be salvaged for reuse.
- Construct new building of similar construction to existing:
  - 2 x 4 construction with truss roof.
  - R38 insulation in walls and ceiling.
  - Plywood interior walls and ceiling.
  - 26-gauge painted metal exterior.
  - Shingle roof with 2' x 4' velux skylight centered over pumps.
  - 3'-0" x 6'-8" hollow metal door.
  - (2) hollow core jam windows.
  - Ceiling, walls, doors, and windows will be painted.
- Provide and install new duplex pump control panel on wall inside pump station.
  - NEMA rated motor starters and breakers.
  - NEMA 3R painted, gasketed enclosure.
  - Pump run lights.
  - HOA selector switches.
  - SCADA outputs.
  - Controller for multi-trode level control probe.

September 26, 2019

- Remount existing SCADA panel and coordinate with Biscoe to integrate to new control panel.
- Remount and reconnect antenna.
- Spread 1 load of stone around structure and drive.
- Place station back into service.
- Remove bypass pumping system.
- Turnover building to Owner.
- Payment & Performance Bond for project.

Total Price: \$95,160.00 This price includes all tax and freight.

**Deduct**

If Payment & Performance Bond is not required, deduct \$2,500.00 from the above price.

**Building Adder**

To provide a split face block building with metal gables, add \$3,500.00 to the above price.

As always we appreciate the opportunity to work with you on this project. If we can be of further service, or if you have any questions, please contact us.

Best regards,

Charles R. Underwood Inc.

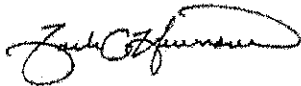

Zach C. Hinnant, PE

INFORMAL BID PROPOSAL

The Contractor shall provide all labor, tools, equipment and materials to complete the "Shady Oak Pump Station Building Replacement Improvements" project. The Contractor shall completely demolish the existing building and provide a replacement building complete with access door, window, electrical connections, and replacement of all control panels and equipment that provide service to the station. The Contractor shall also remove all existing unused electrical equipment and features. The work shall also include a new bypass pumping connection to the existing force main in accordance with the attached detail. All work shall be completed and included in the lump sum price for the work as noted herein, and the project shall be delivered as a complete project as noted. The Contractor shall attach a scope of work with details of the individual work items proposed to this submittal with any exceptions to the intended final product clearly noted and attached to the bid with a detailed description and any financial adjustments noted with the exception.

TOTAL BID AMOUNT .....\$ 81,160 <sup>00</sup>/<sub>100</sub>

Respectfully Submitted:

Carolina Lift Stations  
(Print Company Name)

PO Box 746 / 1303 Hunter St.  
(Street)

James Caldwell  
(Signature)

York, SC 29745  
(City, State & Zip)

James Caldwell, COO  
(Print Name and Title)

79845  
(License Number)

October 1, 2019  
(Date)

Seal if bid is from a corporation:

ATTEST: \_\_\_\_\_  
\_\_\_\_\_  
(Print Name and Title)



## Specialty Covers – SERIES C, R, F, T

## SPECIFICATIONS

### Series F-R Access Door

#### FLOODTIGHT REGULAR

##### Specifications (bullet form)

- Cover leaf: 1/4" (7mm) aluminum diamond plate.
- Angle frame: 1/4" (7mm) aluminum raised curb style frame to be located over existing concrete opening. Units shall be installed to insure minimal water intrusion and/or odor resistance. Reinforced to withstand a 10 foot (3M) column of stationary water.
- Load rating: 625 lbs. psf (28kg. psm), Uniform live load.
- Locking System: aluminum locking lugs welded to the frame and to the cover to work in conjunction with owner supplied padlock.
- Cover equipped with the following Type 316 stainless steel features: heavy duty hinges, tamper proof attaching hardware, automatic hold open arm with aluminum latch.
- Stainless Steel pressure locks.
- Gasket: neoprene.
- Guarantee: Access covers shall carry a lifetime guarantee against defects in material and/or workmanship.

##### Specifications (paragraph form)

The F1R (single leaf) series access frames and covers as manufactured by Halliday Products, Inc. of Orlando, Florida shall have a 1/4" (7mm) thick, mill finish, aluminum frame designed for surface mounting. Door panel shall be 1/4" (7mm) aluminum diamond plate, reinforced to withstand a 10 foot (3m) column of stationary water, or approximately 625 lbs. psf. (28kg. psm) load rating, Uniform live load. The door shall incorporate a 90 degree return flange around the perimeter. Stainless steel pressure locks shall be provided to work in conjunction with a 1/4" (7mm) thick neoprene compression gasket, mounted to the under side of the door, to insure minimal water intrusion and/or odor resistance. Door shall open to 90 degrees and automatically lock with a T-316 stainless steel hold open arm with aluminum release handle. Hinges and all fastening hardware shall be T-316 stainless steel. Unit shall lock with pad lock lugs. Unit shall carry a lifetime guarantee against defects in material and/or workmanship.

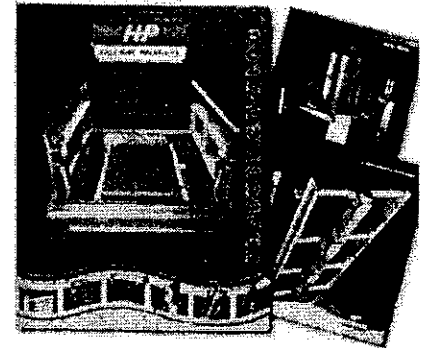

Register for a **FREE CATALOG**  
[Learn more »](#)

Browse our **DIGITAL CATALOG**  
[Click here to view »](#)

#### ADDITIONAL PRODUCTS

[Access Covers »](#)

[Debris Baskets »](#)

[Portable Hoists »](#)

[Manhole Safety Grates »](#)

[Ladders »](#)

[Mixer Mast »](#)

[Slide & Stop Gates »](#)

[Telescoping Valves »](#)

[Guide Rail Brackets »](#)

[Retro-Grate™ »](#)

[Accessories »](#)

[? Have questions?](#)



# SERIES FIR ACCESS DOOR



www.HallidayProducts.com  
 Phone 800-298-1027  
 Fax 407-298-4534  
 Sales@HallidayProducts.com

## STANDARD FEATURES:

- AUTO-LOCK T-316 STAINLESS STEEL HOLD OPEN ARM WITH RELEASE HANDLE
- TYPE-316 STAINLESS STEEL HINGES AND ATTACHING HARDWARE
- STAINLESS STEEL PRESSURE LOCKS
- 1/4" (7 MM) NEOPRENE GASKET
- PADLOCK LUG
- SINGLE LEAF CONSTRUCTION
- 625 LBS. PER SQ. FT. LOAD RATING (28 KG. PER SQ. METER LOAD RATING)
- EXTRUDED ALUMINUM FRAME
- LIFETIME GUARANTEE

## STANDARD SIZES

QTY.	MODEL NO.	A DIM. INCHES (MM)	C DIM. INCHES (MM)	UNIT WT. LBS. (KG.)
	F1R2424	24 (610)	24 (610)	48 (21)
	F1R2430	24 (610)	30 (762)	51 (23)
→	F1R2436	24 (610)	36 (914)	61 (28)
	F1R2442	24 (610)	42 (1067)	77 (35)
	F1R2448	24 (610)	48 (1219)	85 (39)
	F1R3030	30 (762)	30 (762)	54 (24)
	F1R3036	30 (762)	36 (914)	69 (31)
	F1R3042	30 (762)	42 (1067)	77 (35)
	F1R3048	30 (762)	48 (1219)	85 (39)
	F1R3054	30 (762)	54 (1372)	99 (45)
	F1R3060	30 (762)	60 (1524)	106 (48)
	F1R3636	36 (914)	36 (914)	70 (32)
	F1R3642	36 (914)	42 (1067)	89 (40)
	F1R3648	36 (914)	48 (1219)	97 (44)
	F1R3654	36 (914)	54 (1372)	107 (49)
	F1R3660	36 (914)	60 (1524)	104 (47)
	F1R3666	36 (914)	66 (1676)	126 (57)
	F1R3672	36 (914)	72 (1829)	135 (61)

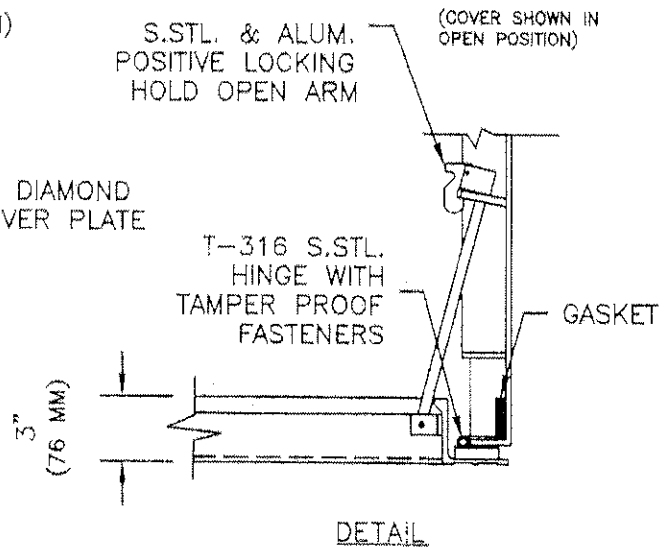
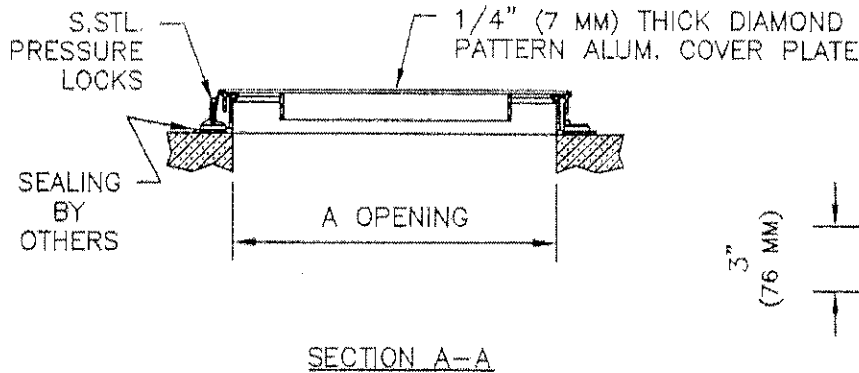
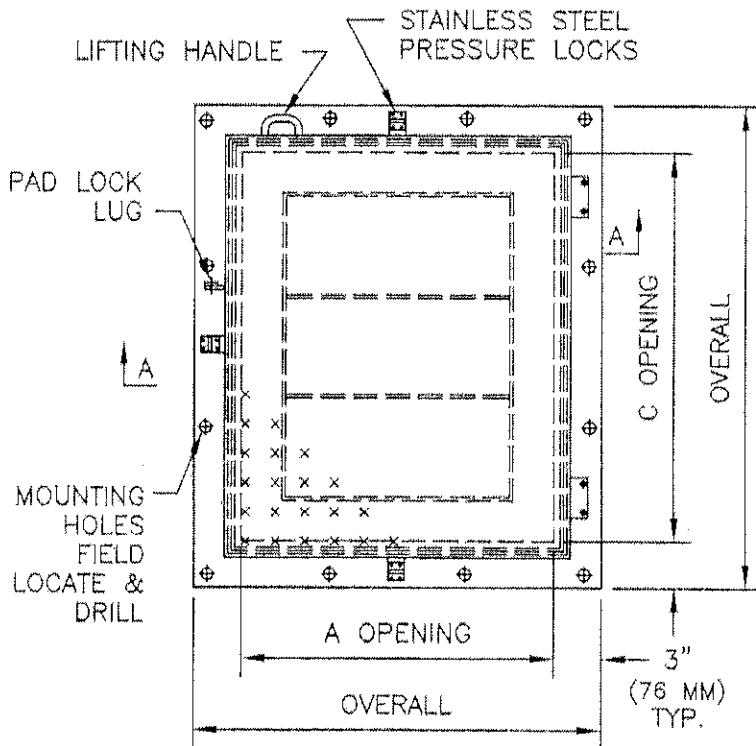

# Access Doors and Options

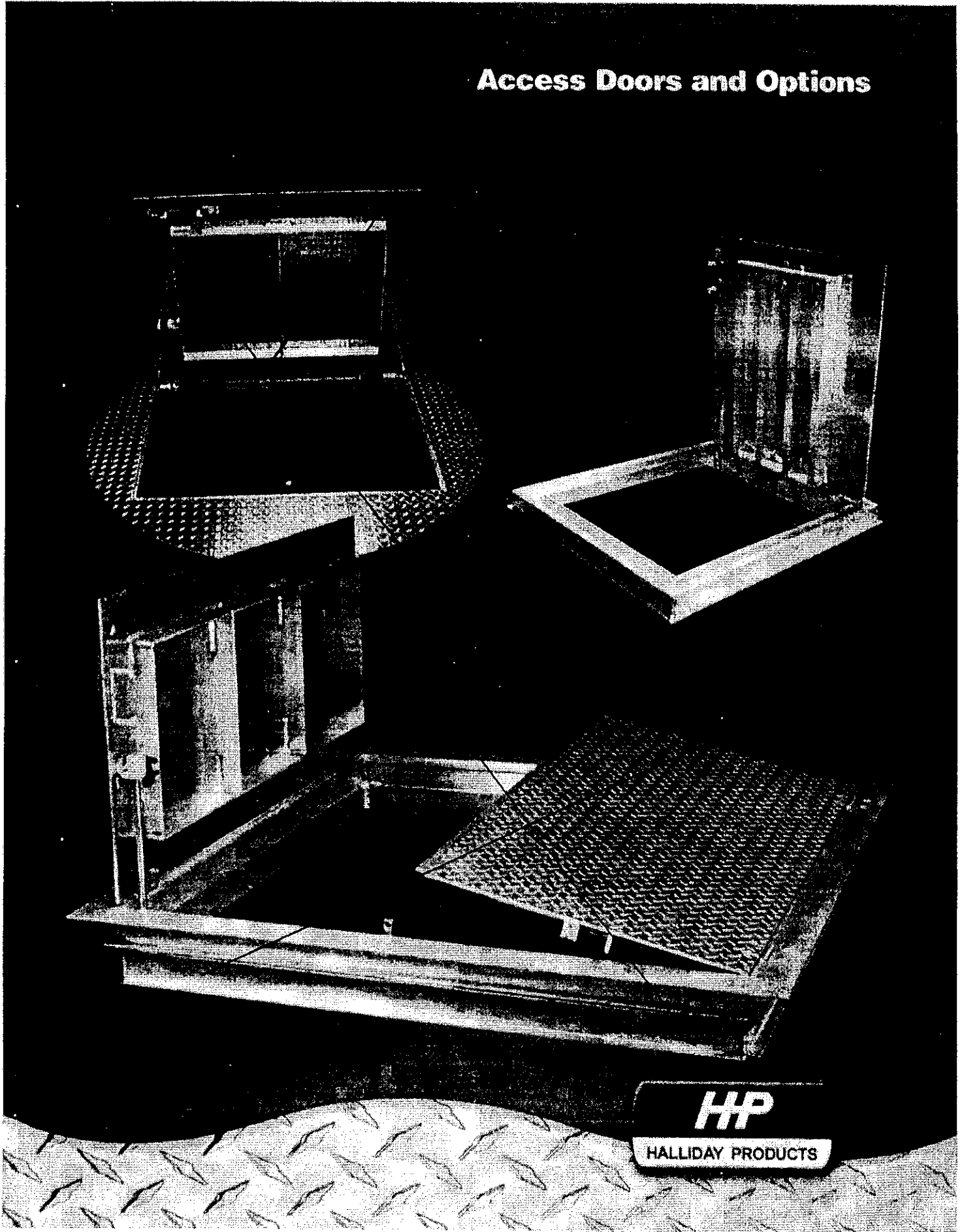

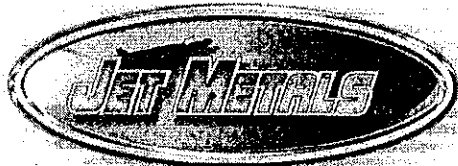

# R and PBR Panel Overview

JET Metals, L.L.C. 1429 North Dave Lyle Blvd, Rock Hill, S.C. Phone: 803/325-8700 www.jetmetals.com

**Slope:** The minimum recommended slope for R and PBR panels is 1:12. JET METALS recommends that in all roof applications sealant be used on sidelaps

**Substrate:** R-Panel is designed to be installed over open structural framing, but can be used with a solid substrate. The recommended substrate is 5/8" plywood with a 30 pound moisture barrier. *PBR-Panel is recommended for roof applications.*

**Coverage:** R and PBR panels are available in a 36" width with a 1 1/4" rib height.

**Length:** Lengths under 5 ft are available with some cutting restrictions. Maximum recommended panel length is 45 ft. Longer panels require additional considerations in packaging, shipping, and erection.

**Availability:** R and PBR panels are available in 26, and 24 gauge. Minimum quantity may apply.

**Application:** Commercial

**Fastening:** Direct fasten ( exposed )

**Fasteners:** Self-Drilling screws for open metal structural framing, woodgrip screws for wood substrate. Quantity and type of fastener must meet necessary loading and code requirements.

## R and PBR Panel Attachment

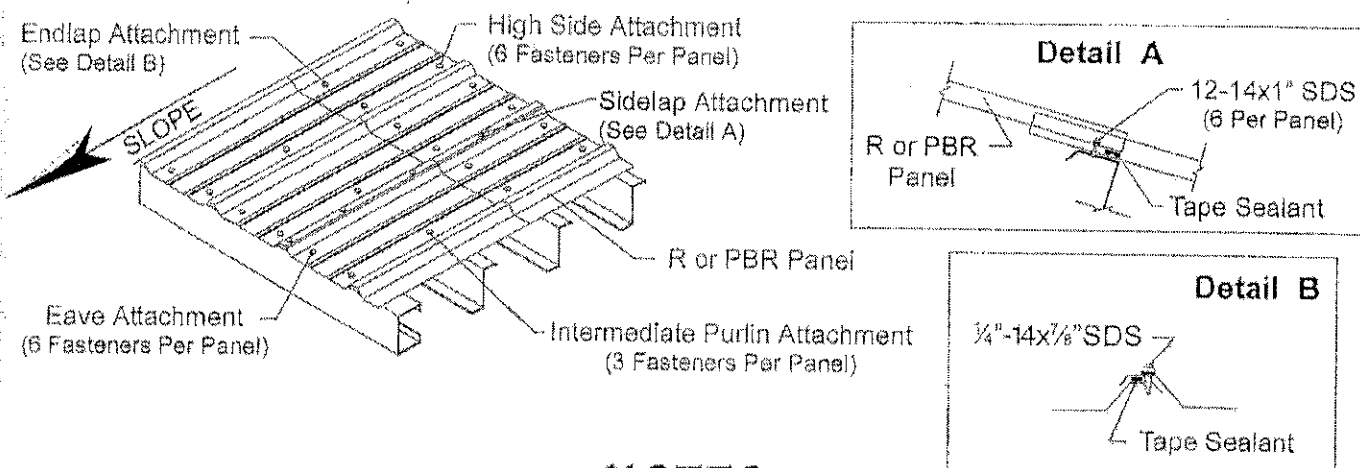

### NOTES:

#### Sidelap

- 1/2"x3/32" Tape Sealer must be installed between weather infiltration point and fastener
- Install 1/4"-14x7/8" Fasteners at 20° on center
- When possible, install panels such that sidelaps are nested away from prevailing winds

#### Endlap

- Tape Sealer must be installed between weather infiltration point and fastener
- Install 12-14x1" SDS on each side of major ribs of panel ( 2SDS per 1")



# R and PBR Panel Overview

JET Metals, L.L.C. 1429 North Dave Lyle Blvd. Rock Hill, S.C. Phone: 803/325-8700 www.jetmetals.com

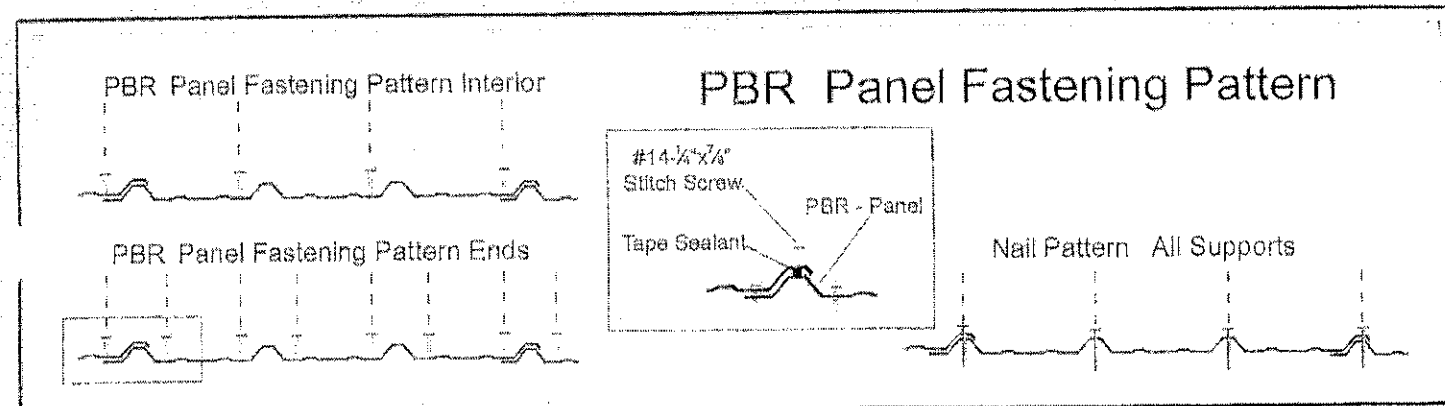
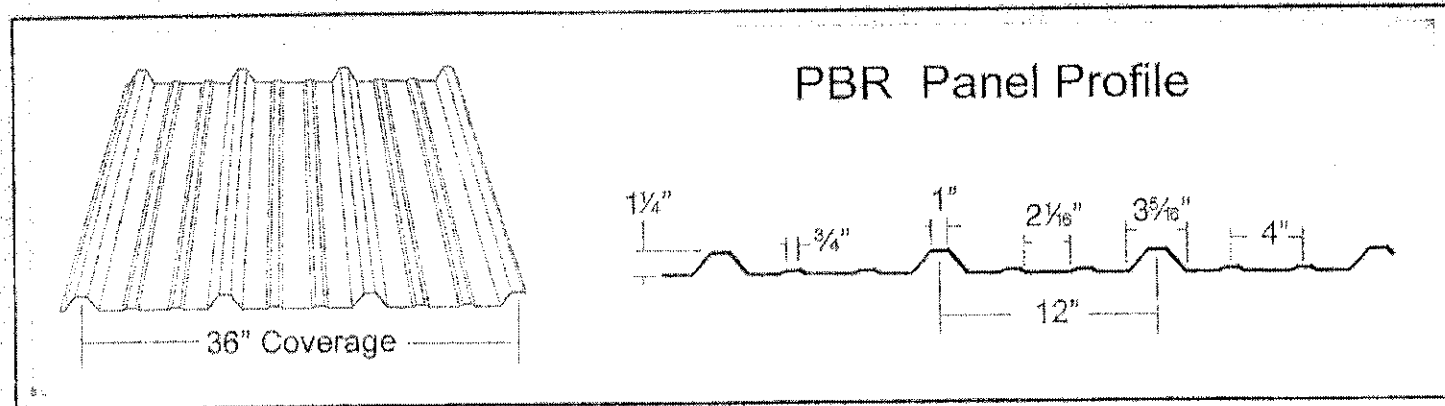
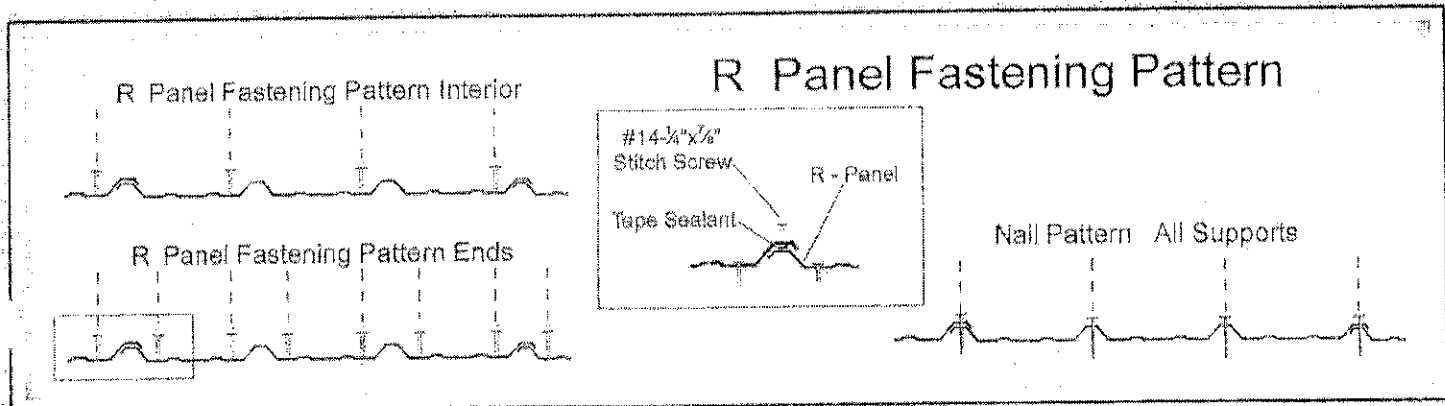
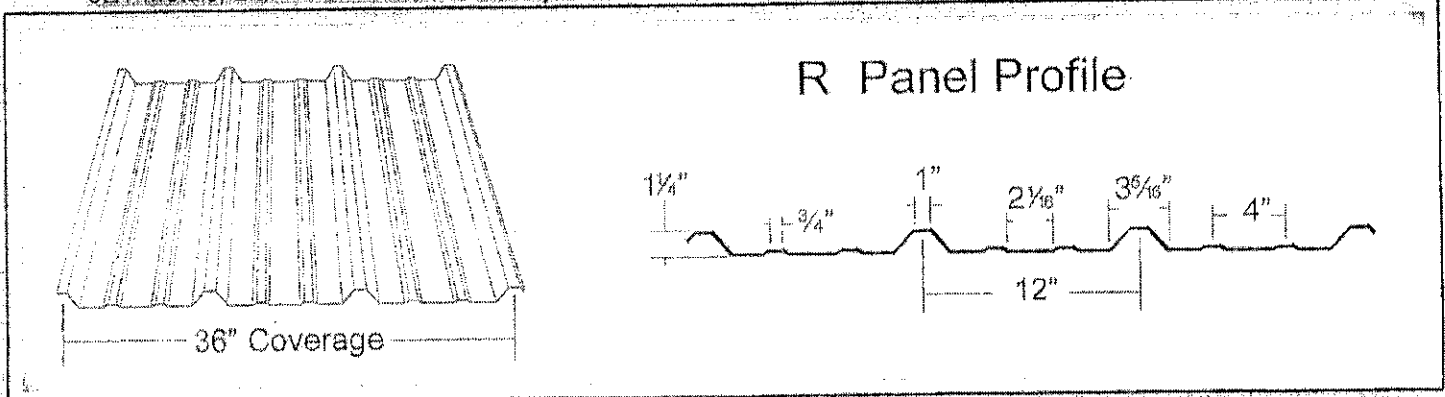

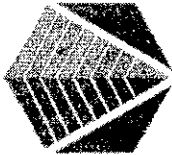







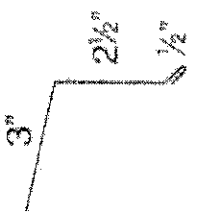

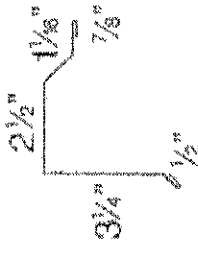

**JET METALS**  
ROOF & WALL SYSTEMS

# STANDARD TRIM

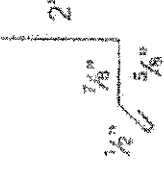
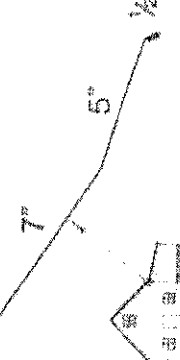
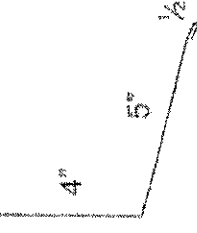
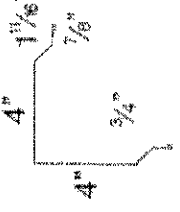
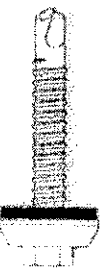
677 Celriver Road  
Rock Hill, SC 29730  
Phone: 803/325-8700  
Fax: 803/325-8705  
www.jetmetals.com

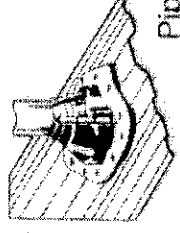
<p>JET 24 Eave</p> 	<p>JET 23 Gable</p> 	<p>JET 37 Hip/Ridge Cap</p> 	<p>JET 22 Gable</p> 
<p>JET 32 Hip/Ridge Cap</p> 	<p>JET 01 W-Valley</p> 	<p>JET 72 Base Guard</p> 	<p>JET 73 Inside Corner</p> 
<p>JET 116 J-Channel</p> 	<p>JET 74 Base Trim</p> 	<p>JET 29 Transition</p> 	<p>JET 36 Sidewall/Endwall</p> 
<p>JET 46 Outside Corner</p> 	<p>Fasteners</p> 	<p>Butyl Tape</p> 	<p>Pipe Boot</p> 
<p>Accessories</p>			<ul style="list-style-type: none"> <li>• Custom Trim</li> <li>• Gutters</li> <li>• Downspouts</li> <li>• Tube Sealant</li> <li>• Closure Strips</li> </ul>

# *Carolina Lift Stations, Inc.*

## **Town of Biscoe, Shady Oak Pump Station Building Replacement Improvements.**

The Contractor shall provide the following items in his submitted scope of work at a minimum:

- 1) Construct new bypass pumping connection on the existing force main discharge from the station near the building and wet well. *Due to visible rock within the work area CLS proposes to install the bypass connection with isolation valve and connection valve inside the building on the vertical section of force main piping and stub-out connection point through the building sidewall. This will also allow for future service of the valves when needed.*
- 2) Establish bypass pump at new connection to be used during construction of the improvements to eliminate any downtime or disruption of service. No wastewater overflows shall occur as a result of the work. Contractor is responsible for cost of bypass pumping. *CLS proposes to include both primary and backup residential grade diesel generators with separate auto controls and alarm telemetry system during period of bypass operations.*
- 3) Demolish existing building, unused electrical components on interior of building and all other non-essential items and dispose of properly. The Contractor shall ensure that the electrical service is properly disconnected prior to coordinating demolition and beginning work on the structure. *CLS proposes to use the service of the Town of Biscoe's preferred electrician for electrical service-related work. Meter can and three-way switch will be preserved for reuse after new building erection.*
- 4) Construct and/or erect a new building enclosure of similar size (12'0" x 12'0"). New building shall be secured to existing concrete and wet well by means of mechanical or adhesive fasteners. The building may be metal built-up building, fiberglass construction, masonry with truss roofing, or prefabricated concrete (Smith Carolina, or equal). The Contractor must note specifics of his materials of construction with his quote. *Due to the unique nature of this application, CLS proposes to prebuild the walls and roof structure of the new building for assembly onsite to reduce both bypass operational duration and exposure of the remaining equipment to weather. See details after Scope of Work responses for materials list of new building.*
- 5) The building shall be equipped with an all-weather access door and two windows to match the existing window dimensions. The building shall have roof hatches centered over the pumps for removal of pumps and motors without damage to the structure. *CLS proposes to install one 36" steel clad*

# *Carolina Lift Stations, Inc.*

*door, two 36" double hung vinyl windows, and one 24" x 36" curb style aluminum hatch for removal of the pump suction piping.*

- 6) Upon completion and/or setting of the building, complete all electrical improvements to include reconnection of all control panel equipment and electrical accessories. The contractor shall install a minimum of four GFCI outlets and proper lighting for the interior and exterior of building. *CLS will provide four GFCI protected convenience outlets within the new building along with one 4' wet area ceiling light and two outside lights (by door and wet well hatch).*
- 7) Contractor shall coordinate removal and updating of control panel for pumps to eliminate unnecessary equipment and install in new panel enclosure. Automatic transfer switch on exterior of building shall be reinstalled and reconnected to the panel in accordance with NEC. All wiring shall be redone, and panels and equipment mounted on wall mount away from the pumps and piping (eliminate existing condition of poor access to pumps blocked by the panel box). *CLS will coordinate restoration of the electrical service with local electrician, relocate Multitrode primary level controller to a more accessible location along rear wall, and mount a new pump starter panel adjacent to the level controller enclosure. Distribution panel will be remounted in its' original location along with meter can and transfer switch.*
- 8) Contractor shall coordinate with Owner to make reconnection to SCADA system for monitoring of the pump station. All work associated with reconnecting and relocation of antenna shall be included. *CLS will complete as specified.*
- 9) Upon completion of construction, provide stone around and leading to structure to repair areas damaged during construction. *Subject to approval of proposed bypass installation method, CLS anticipates minimal disturbance of the grounds except within the immediate area of the building. CLS has included stone for restoration.*
- 10) Coordinate start-up of station to ensure all components are working properly before placing back into service. Upon successful start-up, remove bypass pumping operation and place system into normal operation. *CLS will complete as specified.*
- 11) Final certification -- Contractor shall provide owner with all warranty information and provide building keys and all other pertinent data prior to final payment. *CLS will complete as specified.*
- 12) The Owner and Contractor shall schedule a meeting to review the final work and address any remaining punchlist items prior to final payment. Payment

# *Carolina Lift Stations, Inc.*

requests shall be detailed per the work scope and included a sales tax report for all purchased equipment and materials. *CLS will complete as specified.*

## **Building Materials List**

To facilitate the roof hatch, proposed building will use a lean-to style single slope roof (similar to existing flat roof design) sloped to the rear of the building. Front wall interior height will be approximately 10' and rear wall approximately 8' to provide a 2/12 pitch to the building rear. Roof and siding covering shall be 26 Gauge metal in Polar White, Light Stone, or Galvalume color. Roof shall be decked, felted, and insulated prior to installation of metal roof covering. Facia shall be metal clad with vinyl soffit. Walls shall be R-11 insulated, with interior walls sheathed with pressure treated plywood and lower four feet covered with Reinforced Fiberglass Panels and Flexco vinyl wall base to provide moisture protection during pump repair work. Above 4' in height will be bare pressure treated plywood wall covering. Exterior of building shall be sheathed in pressure treated plywood, moisture barrier, and metal siding and trim to match roof profile and color.

Sill plate, roof deck, exterior and interior sheathing shall be Severe Weather pressure treated lumber. Wall studs, rafters, headers, and facia shall be Spruce, Pine, or Fir lumber as available from local lumber yard.

Roof hatch shall be by Halliday Products, model FIR2436.

Metal roof/siding shall be by Jet Metals, Prepainted Galvalume, PBR panel profile or approved equal.

CLS shall provide one complete pump starter panel (24"x24"x8" NEMA 4 enclosure) to include IEC rated breakers, starter contactors, overload relays, auxiliary contacts, control transformer, and auxiliary relays to provide dry contacts to Multitrode controller for pump run status and overload alarm faults.



INFORMAL BID PROPOSAL

The Contractor shall provide all labor, tools, equipment and materials to complete the "Shady Oak Pump Station Building Replacement Improvements" project. The Contractor shall completely demolish the existing building and provide a replacement building complete with access door, window, electrical connections, and replacement of all control panels and equipment that provide service to the station. The Contractor shall also remove all existing unused electrical equipment and features. The work shall also include a new bypass pumping connection to the existing force main in accordance with the attached detail. All work shall be completed and included in the lump sum price for the work as noted herein, and the project shall be delivered as a complete project as noted. The Contractor shall attach a scope of work with details of the individual work items proposed to this submittal with any exceptions to the intended final product clearly noted and attached to the bid with a detailed description and any financial adjustments noted with the exception.

TOTAL BID AMOUNT .....	\$ <u>126,080</u>
------------------------	-------------------

Respectfully Submitted:

SKC, Inc  
(Print Company Name)

POB 386  
(Street)

Kellie B. Williams  
(Signature)

Seagrove NC 27341  
(City, State & Zip)

Kellie B. Williams-pres  
(Print Name and Title)

39936  
(License Number)

10-1-19  
(Date)

Seal if bid is from a corporation:

ATTEST:

Steve Williams

Steve Williams VP  
(Print Name and Title)

# SKC Inc. UTILITY CONTRACTORS POB 386 Seagrove, NC 27341

Phone: 336-873-9494

"An Equal Opportunity Employer"

Fax: 336-873-9498

Scope of work included in price:

**Building and Site Work:** We propose to furnish and site assemble one (1) 12'-0" x 12'-0" x 8'-6" high OD, (11'-6" x 11'-6" x 8'-0" high interior) "EASI-SET" Precast Concrete Building on the existing concrete slab. 12-16 week from final approval for shipping.

Components & Finishes:

1. 3" Thick exterior wall panels 8'-0" high.
2. 4" to 6" Thick gabled concrete roof slab, (one-section 12'-6" x 12'-6"), post-tensioned with 3-inch overhang typical, with a smooth form finish edge and a turn down edge design to prevent water infiltration. Curbed roof opening provided for hatch installation
3. Brick pattern exterior wall finish stained with H&C Concrete stain. Color chart provided for color selection.
4. Interior surfaces form finished-standard gray concrete, (not painted).
5. Hot Dip Galvanized mild steel brackets and Coil Bolts for Panel Connections.
6. Two 36" x 36" horizontal slider windows
7. One 36" x 36" clear opening Holliday Products F1R aluminum access hatch installed on curbed roof opening.
8. All Precast building joints caulked interior & exterior with Sonneborn Sonolastic NP1 caulking, (standard manufacture color)
9. Door Package: One (1) pair 3'-0" x 6'-8" x 1 3/4" full flush double leaf 18 gauge galvanized steel doors and 16 gauge galvanized steel doorframe provided with our commercial grade door hardware.
10. Site work will include any concrete repairs to slab, seeding and gravel drive repair.

**Emergency Bypass Connection and By Pass Pumping:** Connection will be installed per plan sheet #1 dated September 2019. By- Pass Pumping will be completed with 4-6" pump around system and backup unit.

**Control Panel:**

1 ea Duplex 25.0-HP Pump Control Panel, UL 698A Listed for 240V, 3PH Incoming Power To Include:

- NEMA 4X Stainless Steel Enclosure w/ Aluminum Inner Door & 3-Point Latch
- Lighting Arrestor, & Phase Monitor w/ Fused Protection
- Power Distribution, Neutral & Grounding Blocks
- Control Power Transformer w/ Fused Primary & Secondary
- Pump Circuit Breaker w/ Lockable Disconnect Handles Mounted Through Inner Door
- Control Power Circuit Breaker
- Electronic Overloads & Reset Pushbutton On Inner Door
- Full Voltage Non-Reversing Motor Starter w/ Overload
- Relay Pump Control Logic w/ Alternator
- Heater Strip w/ Thermostat
- Hand-On-Off Switch & Pump Run Indicator Light
- Elapsed Time Meter
- Seal Failure & Motor Over-Temperature Alarms w/ Indicator Lights
- Flashing Alarm Light
- Audible Alarm Horn w/ Silence Pushbutton
- Terminal Blocks, Control Relays, and Fuses/Fuse Blocks As Required
- Dry Alarm Contacts As Required

1 ea Wastewater Level Model: Level-7.5-100, 7.5-Foot FOGRod w/ 100-Foot Cable, Cleaning Bracket, And Level Indicator Transmitter (LIT)

1 ea Equipment Start-Up Service, Testing, & Operator Training – 1-Day, 1-Trip Inclusive

\*\*\*The control panel proposal only includes the components quoted herein and based on our best interpretation of the project limited components specifications. If required, we may have to re-quote the control panel.

A new SCADA system is not included in the above proposal as it is our understanding the old one is to be reused. We will assist in the re-connection and relocation of the antenna.

**Electrical:** Includes disconnecting the power from the existing building and removing all electrical components and re-installing the existing service, panels, relocating the new control panel, inside and outside lighting and GFCI outlets.

**Start Up and Closeout:** Contractor will start station back up, remove all backup pumping equipment and place system in normal operation. Warranty documents and O&M manuals will be provided to owner.



Engineering  
Landscape Architecture  
Surveying

October 8, 2019

Brandon Holland, Town Manager  
Town of Biscoe  
110 W. Main Street  
Biscoe, NC 27209

Re: Recommendation of Award  
Shady Oak Pump Station Repairs  
Town of Biscoe, Montgomery County, North Carolina

Dear Brandon:

Per the Town's request LKC Engineering prepared an Informal Request for improvements to the Shady Oak Pump Station to address concerns from previous storm damage. Prices were received from three (3) direct solicitations with one additional contractor declining to respond to their current workload. Pricing received is summarized below:

Carolina Lift Stations	\$81,160.00
Charles R. Underwood, Inc.	\$95,160.00
SKC, Inc.	\$126,080.00

The informal bids were solicited due to the anticipated cost of the improvements and the nature of the work being heavy maintenance and repairs rather than new construction. As such these bids also had slight variations and bidders were allowed to make qualifications and state the type of repairs for certain portions of the work, for instance type of building materials. Our review did reveal a small variation in the low bidder's quote that we chose to not accept, which will result in them needed to make a slight adjustment.

Carolina Lift Stations has completed similar projects for LKC Engineering and have performed the work with excellent workmanship. Therefore, it is our recommendation that the Town award this work to Carolina Lift Stations for the amended amount based on our final negotiation of the scope. I would also note that work of this nature may encounter unforeseen issues with the age of the station and require some contingencies be made available as the situation may arise.

If you should have any questions or comments, please do not hesitate in contacting this office.

Sincerely,  
LKC ENGINEERING, PLLC

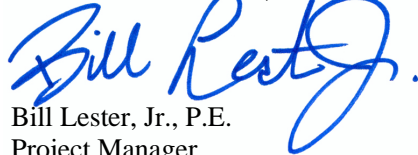

Bill Lester, Jr., P.E.  
Project Manager

Enclosures

## Census Committee Needed

---

Town Manager Holland and Clerk Laura Morton met with Census a representative. We need a group of people that will be willing to serve on this committee. The committee should be comprised of a broad spectrum of government and community leaders from advocacy, education, business, healthcare, and elected official. These trusted voices develop and implement a 2020 Census Awareness Campaign based upon their knowledge of the local community to encourage a response.

- ◆ Elected Official
- ◆ Government Employees
- ◆ Educators
- ◆ Business Owners
- ◆ Healthcare

If you know someone who would like to serve, please contact Town Clerk Laura Morton with their name and contact information. This will be added on the November 11, 2019 meeting agenda.

# 2020 CENSUS:

## FREQUENTLY ASKED QUESTIONS

### **Why should someone choose to work as a Census Taker?**

Census positions provide the perfect opportunity to earn extra income while helping your community. The results of the 2020 Census will help determine your state's representation in Congress, as well as how certain funds are spent for schools, hospitals, roads, and more. This is your chance to play a part in history and help ensure everyone in your community is counted!

### **What are the benefits of working as a Census Taker?**

In addition to supporting your community, census jobs offer great pay every week, flexible hours, and paid training.

### **How does someone apply for a 2020 Census job?**

Applying is easy. Visit [2020census.gov/jobs](https://2020census.gov/jobs) to learn more, then click on Apply Now. Potential applicants can also call 1-855-JOB-2020 (562-2020) or use the Federal Relay Service at 800-877-8339 for TTY/ASCII to learn more or for assistance.

### **What are the application requirements?**

People can apply for 2020 Census work if they are at least 18 years old, a U.S. Citizen, and if they have a valid Social Security number and email address. Males born after Dec. 31, 1959, must also be registered with the Selective Service System or have a qualifying exemption. Please visit [2020census.gov/jobs](https://2020census.gov/jobs) to learn more about specific application requirements.

### **When someone does apply for a 2020 Census job, what sorts of questions are asked?**

As part of the application process, applicants will be asked questions related to their educational, work, and other experiences.

### **What happens once someone is offered a 2020 Census job?**

Potential employees must pass a criminal background check and review of criminal records (including fingerprinting). Once these steps are completed, potential employees will receive information about training.

### **What is required of most 2020 Census employees?**

Employees should have access to a vehicle and a valid driver's license, unless public transportation is readily available. Employees should also have access to an Internet-connected computer (to complete the training process).

### **What can people expect their 2020 Census work schedule to be like?**

Work schedules depend on individual positions. Generally, hours for field positions are flexible. Some positions require work during the day, and other positions require evening and weekend work interviewing the public. In addition, supervisory positions require employees to be available for certain day, evening, and/or weekend shifts.

### **Where will most people work?**

The Census Bureau is committed to hiring Census Takers to work in their own communities.

### **How often will 2020 Census employees be paid?**

Employees are paid weekly, and can expect to receive their first paycheck approximately 10 to 14 days after their first day of work.

### **Will 2020 Census employees be reimbursed for work-related expenses?**

Field employees will be reimbursed for authorized work expenses, like mileage, while conducting 2020 Census work.

### **Will 2020 Census employees be paid during training?**

Yes, 2020 Census employees will be paid during training at a slightly lower rate than their regular hourly rate.



# 2020 CENSUS KEY DATES

## COMMUNITY INVOLVEMENT – OFFICES – DATA COLLECTION OPERATIONS

January 2018 through December 2019	Engage & Educate Local Leaders, Partners & Communities	
January 2019	Early Area Census Offices Open (these offices run the Address Canvass Operation)	
June 2019	Additional Area Census Offices Open (ACOs)	
August 2019 through October 2019	Address Canvassing Operation	
March 2020	Call to Action for Residents to Respond (starting March 23 <sup>rd</sup> )	
February 2020 through June 2020	Group Quarters Operations (Count of Residents in Shelters, Dorms, Nursing Homes, Transitory Locations, Prisons, Military Bases, RV Parks, etc. Local governments & Census identify & plan these operations)	
Mid-March 2020	Residents Invited to Respond	
<b>Individual Housing Units (Hus) Invited by either:</b>		
Mail (to USPS Mailable Addresses)	or Hand Delivery (to Rural/PO Box, non-USPS HU delivery)	
1. Letter Mailed	1. List Housing Units (operation is called Update Leave)	
2. Reminder Postcard	2. Leave Questionnaire (Spanish in certain areas) &	
3. Then Paper Questionnaire	Letter w/other Response Options (internet & Phone	
<b>Options to Self-Respond (all residents will have these 3 options &amp; decide what is best for them)</b>		
Internet	Telephone	Paper
March 23, 2020	Self-Response Begins	
April 1, 2020	Census Day – Reference Date = where you live on April 1	
April 2020	Early Non-Response Follow-up begins (primarily areas around Colleges/Universities where the population leaves before early May)	
May 2020	Non-Response Follow-up (NRFU) begins for households that do not self-respond (Households can continue to self-respond during this time)	
Late August 2020 through September 2020	Areas Census Offices Begin Closing	
August 2020 through December 2020	Quality Evaluation (re-contact of select Housing Units)	
December 31, 2020	Deliver Counts to the President	





## 50 Ways Census Data Are Used

- Decision making at all levels of government.
- Drawing federal, state, and local legislative districts.
- Attracting new businesses to state and local areas.
- Distributing billions in federal funds and even more in state funds.
- Forecasting future transportation needs for all segments of the population.
- Planning for hospitals, nursing homes, clinics, and the location of other health services.
- Forecasting future housing needs for all segments of the population.
- Directing funds for services for people in poverty.
- Designing public safety strategies.
- Development of rural areas.
- Analyzing local trends.
- Estimating the number of people displaced by natural disasters.
- Developing assistance programs for American Indians and Alaska Natives.
- Creating maps to speed emergency services to households in need of assistance.
- Delivering goods and services to local markets.
- Designing facilities for people with disabilities, the elderly, or children.
- Planning future government services.
- Planning investments and evaluating financial risk.
- Publishing economic and statistical reports about the United States and its people.
- Facilitating scientific research.
- Developing “intelligent” maps for government and business.
- Providing proof of age, relationship, or residence certificates provided by the Census Bureau.
- Distributing medical research.
- Reapportioning seats in the House of Representatives.
- Planning and researching for media as backup for news stories.
- Providing evidence in litigation involving land use, voting rights, and equal opportunity.
- Drawing school district boundaries.
- Planning budgets for government at all levels.
- Spotting trends in the economic well-being of the nation.
- Planning for public transportation services.
- Planning health and educational services for people with disabilities.
- Establishing fair market rents and enforcing fair lending practices.
- Directing services to children and adults with limited English language proficiency.
- Planning urban land use.
- Planning outreach strategies.
- Understanding labor supply.
- Assessing the potential for spread of communicable diseases.
- Analyzing military potential.
- Making business decisions.
- Understanding consumer needs.
- Planning for congregations.
- Locating factory sites and distribution centers.
- Distributing catalogs and developing direct mail pieces.
- Setting a standard for creating both public and private sector surveys.
- Evaluating programs in different geographic areas.
- Providing genealogical research.
- Planning for school projects.
- Developing adult education programs.
- Researching historical subject areas.
- Determining areas eligible for housing assistance and rehabilitation loans.

# JOIN THE 2020 CENSUS TEAM

# APPLY ONLINE!



[2020census.gov/jobs](https://2020census.gov/jobs)

---

## Area Census Office (ACO) Vacancies

**Area Census Office Manager (ACOM):** Responsible for the quality and progress of all field and office operations and activities. The ACOM directs Census operations in the local area, including monitoring budgets, schedules, and progress of operations.

**Census Field Manager (CFM):** Responsible for managing field data collection activities associated with the ACO. The CFM will be responsible for managing several hundred field operations staff at peak times. The field operations staff work outside the office, throughout the office's geographic territory. Specifically, the CFM will be responsible for training, supervising, and managing field staff involved in activities such as updating address lists and maps, conducting in-person interviews to gather census data, and conducting other follow-up activities. The CFM will also train, supervise, and manage office staff.

**Lead Census Field Manager (LCFM):** Responsible for managing the CFMs throughout the office geographic territory. The LCFM is responsible for training, supervising and managing CFMs in an ACO. The LCFM will ensure that the CFMs are performing their duties and responsibilities.

**Recruiting Manager (RM):** Responsible for ensuring that qualified applicants are recruited to fill ACO field and office positions. RMs are responsible for the development of an ACO recruiting plan that will allow the office to recruit thousands of applicants throughout the ACO territory. The RM is also responsible for recruiting, training, and managing recruiting support staff, including dozens of field RAs and office support staff.

**Recruiting Assistant (RA):** Responsible for outreach and contacting local organizations to request responding to job advertisements by answering their questions from the public about jobs, qualifications and how to apply. In addition, RAs will conduct formal and informal presentations about census jobs and work at the grass roots level to spread the word about jobs.

**Information Technology Manager (ITM)**: Responsible for managing technological functions used by field and office staff in an ACO. Specifically, the ITM is responsible for troubleshooting, evaluating, analyzing, and coordinating automation operations to support office and field activities. The ITM also supports mobile devices used by field staff. The ITM will train and supervise office staff to assist in the IT support function.

**Administrative Manager (AM)**: Responsible for office administrative activities, including personnel and payroll operations for an assigned ACO. AMs will be responsible for administrative support of all supervisory and staff level positions. The AM will be responsible for processing applications for thousands of applicants, managing applicant selection (telephone interview and job offer), processing personnel actions for several hundred new hires, and processing payroll for several hundred or more employees a week at peak times.

**Office Operations Supervisor (OOS)**: Assists in the management of office functions and day-to-day activities required to support field operations, recruiting, IT support, and administrative activities. The OOS supervises, schedules, and assigns work to clerks and oversees related office operations.

**Clerk**: Performs various administrative and clerical tasks to support various functions, including payroll, personnel, recruiting, field operations, and support functions.

**Census Field Supervisor (CFS)**: Supervises Enumerators/Listers. CFSs train their staff, monitor progress and performance, troubleshoot issues and provide instructions, approve time and expense reports, and may document and recommend termination actions.

**Enumerator/Lister**: Conducts field activities such as updating address lists and maps, conducting in-person interviews to gather census data, and conducting other follow-up activities.

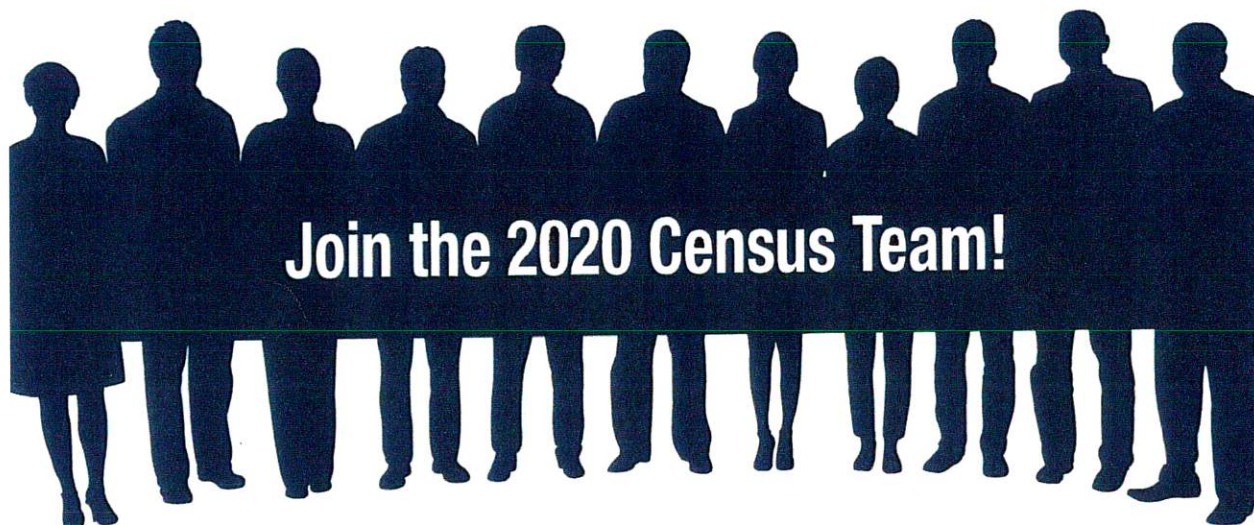

**Join the 2020 Census Team!**

# Apply Online Today!

## 2020census.gov/jobs

### 1-855-JOB-2020

### (1-855-562-2020)

Federal Relay Service: (800) 877-8339 TTY / ASCII

[www.gsa.gov/fedrelay](http://www.gsa.gov/fedrelay)

The Federal Relay Service (FedRelay) provides telecommunications services to allow individuals who are deaf, hard of hearing, and/or have speech disabilities to conduct official business with and within the federal government.

The U.S. Census Bureau is an Equal Opportunity Employer.

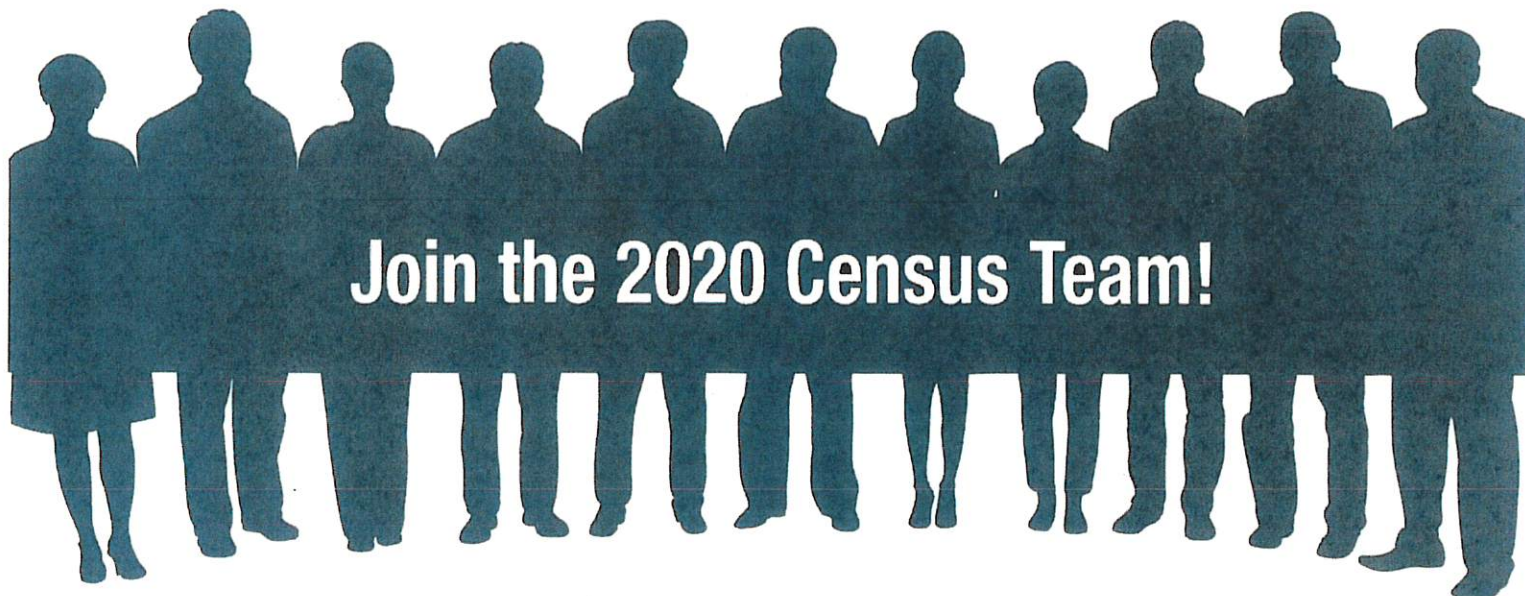

## Join the 2020 Census Team!

## 50 Ways Census Data Are Used

- Decision making at all levels of government.
- Drawing federal, state, and local legislative districts.
- Attracting new businesses to state and local areas.
- Distributing billions in federal funds and even more in state funds.
- Forecasting future transportation needs for all segments of the population.
- Planning for hospitals, nursing homes, clinics, and the location of other health services.
- Forecasting future housing needs for all segments of the population.
- Directing funds for services for people in poverty.
- Designing public safety strategies.
- Development of rural areas.
- Analyzing local trends.
- Estimating the number of people displaced by natural disasters.
- Developing assistance programs for American Indians and Alaska Natives.
- Creating maps to speed emergency services to households in need of assistance.
- Delivering goods and services to local markets.
- Designing facilities for people with disabilities, the elderly, or children.
- Planning future government services.
- Planning investments and evaluating financial risk.
- Publishing economic and statistical reports about the United States and its people.
- Facilitating scientific research.
- Developing “intelligent” maps for government and business.
- Providing proof of age, relationship, or residence certificates provided by the Census Bureau.
- Distributing medical research.
- Reapportioning seats in the House of Representatives.
- Planning and researching for media as backup for news stories.
- Providing evidence in litigation involving land use, voting rights, and equal opportunity.
- Drawing school district boundaries.
- Planning budgets for government at all levels.
- Spotting trends in the economic well-being of the nation.
- Planning for public transportation services.
- Planning health and educational services for people with disabilities.
- Establishing fair market rents and enforcing fair lending practices.
- Directing services to children and adults with limited English language proficiency.
- Planning urban land use.
- Planning outreach strategies.
- Understanding labor supply.
- Assessing the potential for spread of communicable diseases.
- Analyzing military potential.
- Making business decisions.
- Understanding consumer needs.
- Planning for congregations.
- Locating factory sites and distribution centers.
- Distributing catalogs and developing direct mail pieces.
- Setting a standard for creating both public and private sector surveys.
- Evaluating programs in different geographic areas.
- Providing genealogical research.
- Planning for school projects.
- Developing adult education programs.
- Researching historical subject areas.
- Determining areas eligible for housing assistance and rehabilitation loans.

# 2020 CENSUS KEY DATES

## COMMUNITY INVOLVEMENT – OFFICES – DATA COLLECTION OPERATIONS

January 2018 through December 2019

Engage & Educate Local Leaders, Partners & Communities

January 2019

Early Area Census Offices Open (these offices run the Address Canvass Operation)

June 2019

Additional Area Census Offices Open (ACOs)

August 2019 through October 2019

Address Canvassing Operation

March 2020

Call to Action for Residents to Respond (starting March 23<sup>rd</sup>)

February 2020 through June 2020

Group Quarters Operations (Count of Residents in Shelters, Dorms, Nursing Homes, Transitory Locations, Prisons, Military Bases, RV Parks, etc. Local governments & Census identify & plan these operations)

Mid-March 2020

Residents Invited to Respond

### Individual Housing Units (Hus) Invited by either:

Mail (to USPS Mailable Addresses) or

Hand Delivery (to Rural/PO Box, non-USPS HU delivery)

1. Letter Mailed
2. Reminder Postcard
3. Then Paper Questionnaire

1. List Housing Units (operation is called Update Leave)
2. Leave Questionnaire (Spanish in certain areas) & Letter w/other Response Options (internet & Phone)

### Options to Self-Respond (all residents will have these 3 options & decide what is best for them)

Internet

Telephone

Paper

March 23, 2020

Self-Response Begins

April 1, 2020

Census Day – Reference Date = where you live on April 1

April 2020

Early Non-Response Follow-up begins (primarily areas around Colleges/Universities where the population leaves before early May)

May 2020

Non-Response Follow-up (NRFU) begins for households that do not self-respond (Households can continue to self-respond during this time)

Late August 2020 through September 2020

Areas Census Offices Begin Closing

August 2020 through December 2020

Quality Evaluation (re-contact of select Housing Units)

December 31, 2020

Deliver Counts to the President





## APPLY IF:

- You are at least 18 years old.
- You have a valid Social Security number.
- You are a U.S. citizen.
- You have a valid email address.
- You are registered with the Selective Service System, or have a qualifying exemption, if you are male and were born after Dec. 31, 1959.



## BECOME A CENSUS TAKER AND GET PAID TO HELP YOUR COMMUNITY

Learn how you can help collect important data that will determine your state's representation in Congress, as well as how funds are spent in your community on things like roads, schools, and hospitals.

For more information or to apply online, visit [2020census.gov/jobs](https://2020census.gov/jobs) or call **1-855-JOB-2020**.

# BE A CENSUS TAKER



## IF OFFERED A JOB:

- You must pass a criminal background check and review of criminal records (including fingerprinting).
- You must be available to work flexible hours, including days, evenings, and weekends.



## MOST JOBS REQUIRE EMPLOYEES TO:

- Have access to a vehicle and a valid driver's license, unless public transportation is readily available.
- Have access to a computer with Internet (to complete training).

## APPLY ONLINE! [2020census.gov/jobs](https://2020census.gov/jobs)

### 2020 Census jobs provide:

- ✓ Great pay
- ✓ Flexible hours
- ✓ Weekly pay
- ✓ Paid training

Federal Relay Service:  
1-800-877-8339 TTY/ASCII  
[www.gsa.gov/fedrelay](https://www.gsa.gov/fedrelay)

The U.S. Census Bureau is an Equal Opportunity Employer.

D-496

United States  
**Census  
2020**



## HOW DO I APPLY FOR A 2020 CENSUS JOB?

Applying is easy.

Click on Apply Now at [2020census.gov/jobs](https://2020census.gov/jobs)

As part of the application process, you will be asked to respond to questions that relate to your educational, work, and other experience.

If you need help, just call 1-855-562-2020 or use the Federal Relay Service at 1-800-877-8339 for TTY/ASCII.



JOIN THE 2020 CENSUS TEAM AND **BE A CENSUS TAKER**



## WHAT WILL THE WORK BE LIKE?

### What can I expect my work schedule to be like?

If hired, your work schedule will depend on your position. Generally, hours for field positions are flexible. Some field positions require you to work during the day. Other positions require evening and weekend work interviewing the public.

Supervisory positions require employees to be available for certain day, evening, and/or weekend shifts.

### Where will I work?

The Census Bureau is committed to hiring census takers to work in their own communities.



## HOW WILL I GET PAID?

### How often will I be paid?

Employees are paid weekly and can expect to receive their first paycheck approximately ten to fourteen days after their first day of work.

### Will I be reimbursed for work-related expenses?

Field employees will be reimbursed for authorized work expenses, like mileage, incurred while conducting Census work.

### Will I be paid during training?

You will be paid during training at a slightly lower rate than your regular hourly rate.



APPLICATION FOR A CONDITIONAL USE PERMIT

Date 09/23/2019

Applicant LECRAW ENGINEERING Owner CAROLINA FRANCHISE HOLDINGS

Address 3475 CORPORATE WAY, SUITE A, DULUTH, GA 30096 Address 300 GALLERIA PARKWAY, ATLANTA, GA 30339

Telephone 678.257.1905 Telephone 646.462.5481

Property Location 101 MONTGOMERY CROSSING  
(Street Address)

Description of Property 1.13 ACRES LOCATED AT THE SOUTHWEST INTERSECTION OF MONTGOMERY CROSSING  
AND HIGHWAY 27

\*Attach any maps, site plans, or other information that describes proposed use

Tax Map 7568 09 26 4470 Block \_\_\_\_\_ Lot \_\_\_\_\_

Lot Size 44,131 S.F. (Square Feet) Zoning District HB

Number of Building /Units 1

Estimated cost of project \$1,000,000

\*This application must be filed with a zoning official at least ten (10) days prior to the meeting at which time the application is to be considered.

Do not write below this line -- For Zoning Official use only.

Fee Collected \$ \_\_\_\_\_ Date \_\_\_\_\_

Date for Public Hearing Nov 11, 2019



Zoning Official Signature

- (3) Copies
- Original - File
- Copy # 1 - Applicant
- Copy # 2 - Clerk
- Copy # 3 - Auditor

TOWN OF BISCOE  
ZONING PERMIT APPLICATION

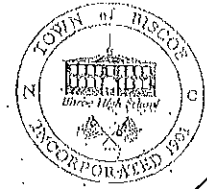

Parcel ID #: 7563 09 26 4470

Zoning District: HB

Date: 9/23/19

Property Address: 101 MONTGOMERY CROSSING

If corner lot check here

Name of Subdivision: N/A

Section or Phase:

Lot(s) #:

**APPLICANT INFORMATION:**

Name: LECRAW ENGINEERING

Address: 3475 CORPORATE WAY, SUITE A, DULUTH, GA 30096

Phone: 678.257.1905

**PROPERTY OWNER INFORMATION (IF APPLICABLE):**

Name: CAROLINA RE HOLDINGS, LLC

Address: 300 GALLERIA PARKWAY, ATLANTA, GA 30339

Phone: 646.462.5481

**PURPOSE FOR APPLICATION (Check all that apply):**

- Single Family Residential Construction
- Multi-Family Residential Construction  
No. of Units \_\_\_\_\_
- Enclosed Addition to Structure \_\_\_\_\_ ft x \_\_\_\_\_ ft
- Detached Accessory Building \_\_\_\_\_ ft x \_\_\_\_\_ ft
- Deck \_\_\_\_\_ ft x \_\_\_\_\_ ft
- Manufactured Housing Setup: Model Year: \_\_\_\_\_ Size: \_\_\_\_\_ ft x \_\_\_\_\_ ft (Attach copy of title)
- Other \_\_\_\_\_
- Fence \_\_\_\_\_ ft height
- Pool (In-Ground)
- Sign (Check Type)
- Free Standing
- Wall/Roof
- Off Site
- Business / Commercial \*
- Occupy New Building
- Occupy Existing Building
- Change in Use
- No Change in Use
- Construct New Commercial Building

• PROPOSED NAME OF BUSINESS: BURGER KING

• PROPOSED USE OF BUILDING: COMMERCIAL RESTAURANT - FAST FOOD

**CONTRACTOR / BUILDER INFORMATION**

Name: TBD

Phone:

License #

Address:

**PLOT PLAN OR SITE PLAN (\*\*Required before approval\*\*):**

Attach map or hand drawn sketch of lot and or sign(s) from survey if possible; showing all dimensions of existing buildings and proposed construction including parking layout. Drawing must include all dimensions between existing & proposed structures and property lines. \*Front yard measurements must be made from right of way line.

**APPLICANT'S AFFIDAVIT:**

To the best of my (our) knowledge, the above statements and attached plot plan are in all respects true and accurate descriptions of the existing status and proposed plans for the property identified in this application:

Applicant's Signature

09/23/19

Date

Property Owner's Signature

Date

Zoning	Lot Dimensions		Setbacks					Building Height Max
	Size Min.	Width Min.	Front	(Local Street)	Back	Side	Corner	
AR	1 Aero.	110 ft	50 ft	35 ft	25 ft	15 ft	35 ft	35 ft
SR	20,000 sqft	90 ft	50 ft	35 ft	25 ft	15 ft	35 ft	35 ft
R-12	12,000 sqft	75 ft	50 ft	35 ft	20 ft	12 ft	30 ft	35 ft
R-8	8,000 sqft	60 ft	50 ft	25 ft	20 ft	9 ft	25 ft	35 ft
CC	5,000 sqft	25 ft	12 ft	Avg.	15 ft	4 ft	12 ft	35 ft
HB	20,000 sqft	90 ft	50 ft	35 ft	20 ft	10 ft	35 ft	35 ft
LI	20,000 sqft	90 ft	50 ft	20 ft	30 ft	20 ft	35 ft	35 ft
HI	20,000 sqft	90 ft	50 ft		30 ft	20 ft	35 ft	35 ft
AI	20,000 sqft	90 ft	50 ft		30 ft	20 ft	35 ft	35 ft
RB	Residential - R-12			Business - HB				

Sign (Sq ft. if applicable)	Sign (Sq ft. if applicable)	
	Required	Proposed
Ground		
Wall		
Freestanding		

Parking		
	Required	Proposed
# Spaces	13	37
# Standard	12	35
# Handicapped	1	2

Based on the information hereby furnished to me and my knowledge of the Town of Biscoe's Zoning Ordinance, I hereby:

\_\_\_\_\_  
Approve

\_\_\_\_\_  
Disapprove

\_\_\_\_\_ this Zoning Compliance Application.

Comments / Conditions:

\_\_\_\_\_

\_\_\_\_\_

\_\_\_\_\_

\_\_\_\_\_  
Signature of Zoning Administrator

\_\_\_\_\_  
Date

Town of Biscoe, Planning & Zoning  
110 West Main St  
Biscoe, NC 27209

PO Box 1228, Biscoe, NC 27209  
☎ (910) 428-4112  
☎ (910) 428-3975  
✉ [manager@townofbiscoe.com](mailto:manager@townofbiscoe.com)

**Permit Fees**

- Residential \$25.00 \_\_\_\_\_
- Commercial \$25.00 \_\_\_\_\_
- Industrial \$25.00 \_\_\_\_\_

